

## Contents

<b>CHAPTER 1. GENERAL INTRODUCTION OF RTP1043.....</b>	<b>3</b>
1.1 FUNCTIONS.....	3
1.2 GENERAL SPECIFICATION.....	4
1.3 NAME OF COMPONENTS.....	4
1.4 DIMENSION AND INSTALLATION GUIDE.....	7
<b>CHAPTER 2. THE EDITING SOFTWARE TPCONFIG.....</b>	<b>9</b>
2.1 GENERAL INTRODUCTION OF TPCONFIG.....	9
2.1.1 About the Project and Window.....	9
2.1.2 Window Contents.....	9
2.1.3 Flowchart of Using TPConfig.....	9
2.1.4 Installation of TPConfig Software.....	9
2.2.1 Create a New Project.....	10
2.2.2 Making Basic Window.....	13
2.2.3 Configuration of RTP1043.....	14
2.2.4 Text.....	17
2.2.5 Dynamic Text.....	19
2.2.6 Function Keys (for window jumping/characters setting/position setting).....	21
2.2.7 Data Display.....	25
2.2.8 Data Setting.....	28
2.2.9 LED.....	30
2.2.10 Function Keys (for controlling the status switches).....	34
2.2.11 Bar Graph.....	36
2.2.12 Trend Line.....	37
2.2.13 Alarm List.....	39
2.3 PROJECT SAVING.....	43
2.4 OFFLINE SIMULATION.....	44
2.5 DOWNLOAD WINDOW.....	44
<b>CHAPTER 3. MANIPULATION.....</b>	<b>46</b>
3.1 COMMUNICATION.....	46
3.2 SHIFTING THE WINDOWS.....	46
3.3 PASSWORD.....	46
3.4 CHANGING THE DATA.....	48
3.5 CONTROLLING THE SWITCHES.....	48
<b>CHAPTER 4. CONNECTION WITH PLC.....</b>	<b>50</b>
4.1 RIEVTECH.....	50
4.2 MITSUBISHI FX SERIES.....	58
4.3 SIEMENS S7-200 SERIES.....	59
4.4 OMRON C SERIES.....	60
4.5 MODBUS RTU.....	61

---

4.6 DELTA DVP SERIES.....	62
4.7 PANASONIC FP SERIES.....	63
4.8 LG MASTER-K CNET SERIES.....	64
4.9 LG SERIES SUPPORTING MODBUS PROTOCOL.....	65
4.10 LG MASTER-K 120S PROGRAMMABLE PORT.....	66
4.11 FACON SERIES.....	66
4.12 KOYO S SERIES.....	67
<b>APPENDIX: SYSTEM SPECIAL REGISTER DEFINITION.....</b>	<b>69</b>

# Chapter 1. General Introduction of RTP1043

## 1.1 Functions

RTP1043 is a small Human-Machine Interface that is used with many kinds of PLC (or the other intelligent controllers with communication ports). With RTP1043, both the values of the PLC inner registers and the relays status of PLC can be monitored or changed through texts or LEDs. So the operation of the machines or the devices is more easy and convenient.

RTP1043 programmable text displayer has many features:

- 32 Bit 72MHz ARM RISC CPU is used, ARM CORTEX-M3, fluent interface running.
- Standard COM0: RS232/485/422, COM1: RS232 double-line communication, and it can work with different PLCs or controllers.
- PLC communication supports automatic batch reading, with fast communication speed.
- Configuration can be downloaded rapidly by USB connection, convenient for testing, upgrading and batch production.
- Metal shrapnel film button, with long shelf-life nearly several million times.
- Equipped with full standard real-time clock.
- Wide working temperature, from -20~70C.
- Intuitive design- Seeing is getting.
- Supporting offline simulation function, convenient procedure testing.

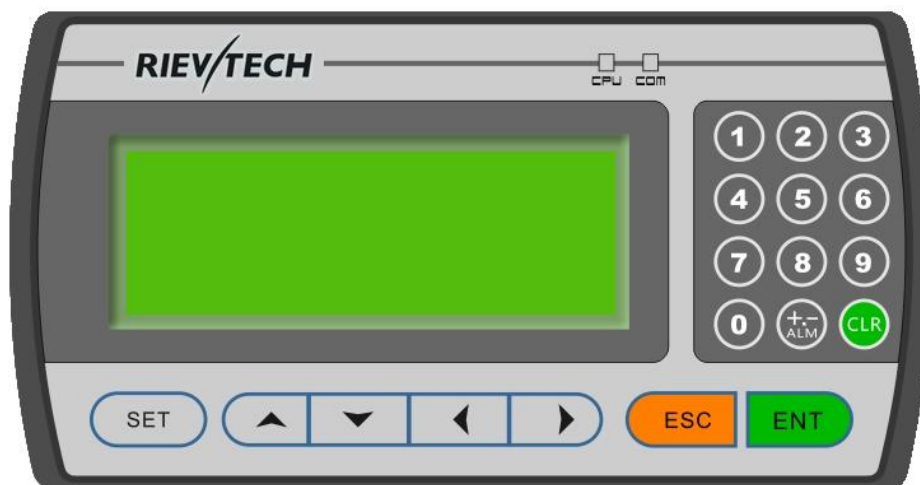

- Supporting Windows and vector fonts, can input or indicate any language. Minimum 6\*8 lattice can be supported for English input. Minimum 12\*12 lattice can be supported for Chinese input. Maximum 5 lines of Chinese characters can be indicated. Maximum 8 lines of English characters can be indicated. Maximum 32\*32 lattice can be supported.
- PLC communication supports automatic batch reading, with high communication speed.
- Supporting multi-language input and the input and indication of languages under any operation system.
- Supporting 8-level user password levels and separate password level setting.
- Powerful function keys, supporting values setting, increasing or decreasing, images skipping, entering or leaving etc setting function.

- Adding ASII indicating components, supporting the indication of English and Number online, convenient for serial NO. and code indication etc.
- Supporting events registering, alarm supporting level position and characters trigger, can customize alarm information nimbly.
- Directly connection with Siemens S7-300 without adapters.

## 1.2 General Specification

### ■ Electric Specification

**WARNING: The product may be damaged if the input voltage is out of range or the positive and negative poles are connected incorrectly.**

Input Voltage	DC12V-DC24V
Power Consumption	<2W (TYP1.5W)
Max. Power Cut Time	<20ms
Max. Voltage	AC1000V-10mA 1min.(between signal and GND)
Insulative Resistance	DC500V-about 10MΩ (between signal and GND)

### ■ Ambient Requirement

Operation Temperature	0~50°C
Storage Temperature	-20~70°C
Ambient Moisture	20~90% (no condensation)
Vibration Resistance	10~25Hz(Max. 2G for 30 min. in any of the X,Y,Z axis)
Interference Resistance	Voltage Noise: 1500Vp-p Pulse period: 1us, lasting for 1s
Atmosphere	No corrosive gas
Protection Structure	IP65 (Front board)

## 1.3 Name of Components

On the front panel of RTP1043, there is a LCD display and 19 thin film switches. The keys have a good touch feeling, and they are durable and reliable. Besides being used for the basic functions, all the 19 keys can be set to execute specific functions, for example: the windows jumping directly or parameters status setting etc. 0~9 numerical keys can be customized for the symbols, other ALM key, +/-key and decimal key can be integrated together.

The front panel of RTP1043 programmable text displayer is shown as following picture:

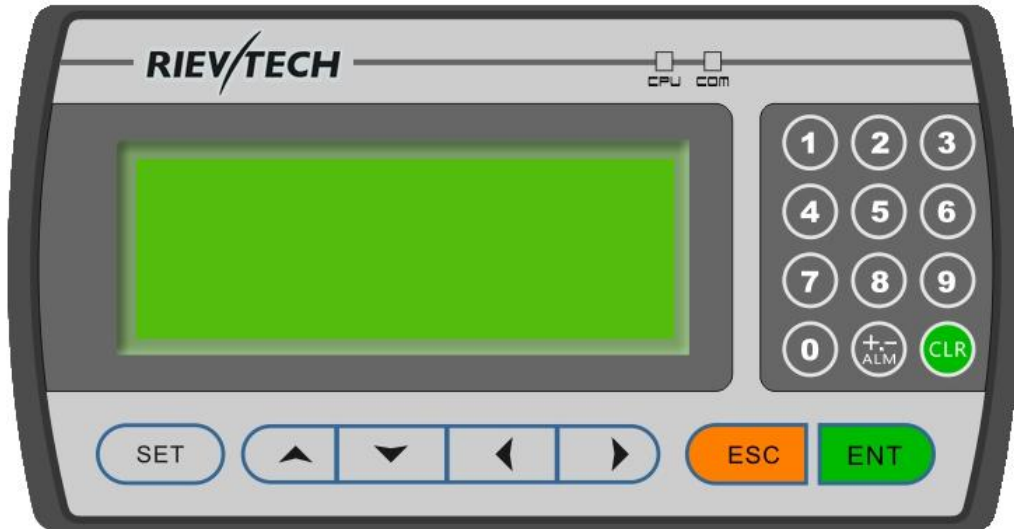

All the 19 function keys can be defined to execute specific functions, for example, Bit setting, Bit resetting, value setting, window jumping etc.. For the undefined keys can only execute basic functions including the registers setting, the initial window returning and the current window to the previous/next window jumping.

**The basic functions of the function keys:**

KEY	BASIC FUNCTION
[ESC]	When pressed, the RTP1043 will return to system initial window and the data just input will be deleted. The user can designate the system initial window during the window making procedure. Usually the Main Menu window or the most-frequently-used window is set to be the initial window.
[ALM]	When pressed, the RTP1043 will shift to the predefined alarm list information window. It can also be defined as a specific function key, can input $\pm$ and decimal point.
[←]	Left shift the digit being edited when changing the register data. When pressed, the digit twinkling will be shifted to the left one.
[→]	Right shifting the digit being edited when changing the register data. When pressed, the digit twinkling will be shifted to the right one.
[↑]	Jump to the previous window. The number of the previous window is designated in the <i>Window Attribute</i> option (default value is the result of subtracting 1 from the current window number). In the data setting mode, pressing it can add 1 to the digit being edited. The value will increase from 0 to 9, then return to 0..... If it is 16-digit, the value is 0→9→A→F→0.....
[↓]	Jump to the next window. The number of the next window is designated in the <i>Window Attribute</i> option (default value is the result of adding 1 to the current window number) In the data setting mode, pressing it will subtract 1 from the digit being edited. The value will decrease from 9 to 0, then return to 9.....

<p>[SET]</p>	<p>Press it to enter the mode for editing the value of registers. The register being operated is displayed in reverse color. The digit being edited is flickeringly displayed. If the current window contains no register setting components, no operation will be executed. When [SET] is re-pressed before [ENT] is pressed, the edition done to the current register will be canceled. The user can continue to operate the next data register.</p> <p><b>NOTE: The function of register setting for [SET] can NOT be disabled by the user-defined function.</b></p>
<p>[ENT]</p>	<p>In register setting mode, pressing it means the edition on the current register is finished. The edited data will be saved. Then the edition will move to the next register. After the edition on the last register on the current window has been finished, it will quit from the register setting mode.</p>

**NOTE: Except for the [SET] key, if there is a conflict between the basic function and the user-defined function for the same key, the basic function will be disabled. The basic function of register setting for [SET] has the highest priority. Although it can be defined to execute other functions, the register setting function will not be disabled. So if it is necessary to execute the function for setting register, please don't define [SET] for other functions.**

There is a power supply port, a COM port, USB port and a contrast adjusting potentiometer on the back side of RTP1043.



On the back side of the product (back view), there is a DC power supply port and a 9-pin D-shape male socket as the COM port. The RS232, RS485 and RS422 COM port is built in the 9-pin D-shape socket. COM0 port can be RS232/RS422/RS485, and COM1 port can be RS232. To download the window data, connect the USB client port and the USB host port of PC with USB downloading cables. To communicate with PLC, select the proper connection mode in the configuration software according to the type of the PLC.

To adjust the contrast of the display, turn the contrast adjusting potentiometer on the right side of RTP1043 (back view) with a small screwdriver.

The display of RTP1043 is equipped with a LED background light. When any key is pressed, the light will turn on. In default conditions, the light will turn off automatically if there is no operation in 3 minutes(default set).

**Pin Definition of the Serial Port of RTP1043:**

PIN	DEFINITION
1	TX+(COM0 RS485)
2	RXD(COM0 RS232)
3	TXD(COM0 RS232)
4	TXD(COM1 RS232)
5	GND
6	TX-(COM0 RS485)
7	RXD(COM1 RS232)
8	RX-(COM0 RS485/A)
9	RX+(COM0 RS485/B)

- Notes:**
1. COM0 RS232 ports are 2, 3,5 pins.
  2. COM0 RS422 ports are 1,6,8,9,5 pins.
  3. COM0 RS485 ports are 8,9,5 pins.
  4. COM1 RS232 ports are 4, 5, 6 pins.

**1.4 Dimension and Installation Guide**

Dimension of RTP1043 (L\*W\*H): 185×96×36 (mm).

Dimension of the installation hole is 165x86 (mm)

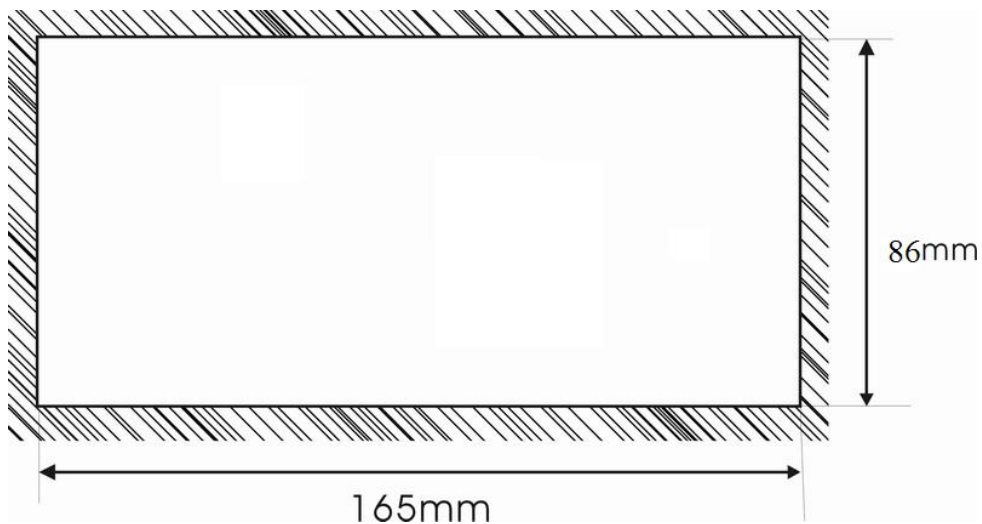

Four ferric installation screws are included in the accessory package of RTP1043. There are four rectangular holes for fixing the RTP1043 on the two sides of the RTP1043, two on the top and two on the bottom. Fix the RTP1043 in the hole on the controlling cabinet with the screws. The procedure is listed as below:

- Make a rectangular hole on the front panel of the controlling cabinet according to the dimension in the figure above.
- Insert the displayer bottom into the hole of the cabinet.
- Insert the screws into the fixing hole on the flanks of the RTP1043 and fasten them;

- Connect the displayer and the COM port of PLC with a cable. The cable can be provided by the manufacturer of the RTP1043 or be made by the user according to the Connection Guide provided in this manual. Switch on the 24-V DC power supply to start the system.



## Chapter 2. The Editing Software TPConfig

### 2.1 General Introduction of TPConfig

TPConfig is the specific configuration software for the programmable text displayer RTP1043. It can run on the WINDOWS 98/2000/XP/WIN 7 platforms. It is easy to study and convenient to use. The user can input English/Chinese characters directly.

#### 2.1.1 About the Project and Window

The basic element of a project is the window. All the windows for one certain project are saved in a single project file. Every window is made to execute some certain functions. By arranging the windows, the user can jump from one window to another. The application project file is composed of all the windows.

#### 2.1.2 Window Contents

After opening a project, the user can “start” or “open” a window. The user can put some elements such as characters (English or Chinese), LEDs, switches, data indicating boxes and jump keys on every window. Jumping between different windows is allowed. The operator can carry on the operations such as data monitoring, parameter setting, switch controlling and alarm list monitoring.

#### 2.1.3 Flowchart of Using TPConfig

The basic flowchart of using TPConfig is shown in the following figure:

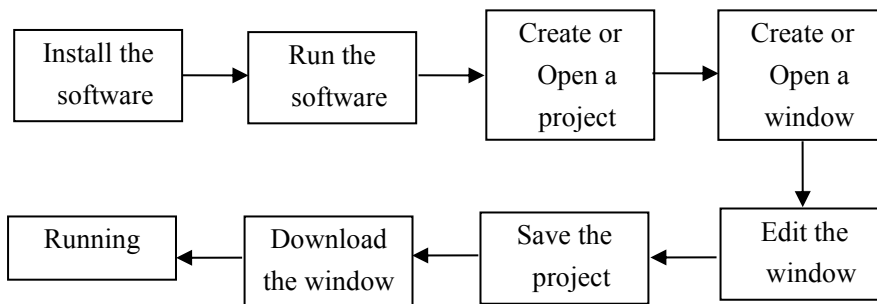

#### 2.1.4 Installation of TPConfig Software

1. Click “TPConfigEN\_Setup.exe” to install the software
2. Then click “Next”, choose the software installation route.
3. Then click “Install”, then the software will be installed according to the installation route.
4. Click the “Finish”, then the TPConfig series text displayers’ software can be used.

**Notes:** The drive of USB downloading line will be installed automatically during software installation, so no need install the drive software of USB downloading line manually. After connecting RTP1043 and computer with USB downloading line, then “Flexem USB” device can be found in the “Device Manager” as below:



## 2.2 Editing the User's Window

### 2.2.1 Create a New Project

Run the software TPConfig and create a project, after which a window editor will be showed on the screen.

On the top of the editor, there is the menu and the toolbar. The window numbers and window descriptions are listed in the table on the left of the editor.

- **Window:**







List the serial number of all the windows included in the project. It is helpful for finding the window quickly and create a new window.





























- **Description:**

A simple description of the window function.

The window-editing region is in the center of the editor. There is a grid of white dots in the display region. The distance between every two rows and two columns is 16 points. The whole region is a matrix of 192\*64 points. The user can refer to the dots nearby to align the components when laying or moving them. If the user move a component by dragging it with the cursor, each time the component will move across the distance which is a multiple of 4 (for example, 4,8,16.....). When necessary, change X and Y positions of the components to locate them in arbitrary positions.

The table below is the description of all the buttons in the toolbar:

Button	Function
	Create a new project
	Open project
	Save project
	Cut the text in the textbox, also can be used to delete components
	Copy the text in the textbox
	Paste the text to the toolbox
	New window, the function is same to the "create" button in the

	window
	Change a window with the copy of another one
	Delete the current window
	Delete the selected text
	Indicate/hide all IDs of text
	Alarm settings, definition of alarm trigger condition and text contents
	Global settings, including settings of initial window, password, PLC controlling window automatic page turning etc
	Download the project to RTP1043 through the USB port on PC
	Language settings: set the language and characters
	Settings of communication parameters
	Serial switching
	Offline simulation
	The selected components will move to the left for one pixel for one click
	The selected components will move to the right for one pixel for one click
	The selected components will up for one pixel for one click
	The selected components will down for one pixel for one click
	The selected components will move to the topside
	The selected components will move to the bottom
	The selected multi-components array left-aligned
	The selected multi-components array vertical centering
	The selected multi-components array right-aligned
	The selected multi-components array horizontal centering
	The selected multi-components array low-end alignment
	The selected multi-components array at equal horizontal distance
	The selected multi-components array at equal vertical distance
	The selected multi-components set at equal width.
	The selected multi-components set at equal height.
	The selected multi-components set at equal size.

Press  or activate [File]->[Create Project] command in the menu to pop up a dialog box:

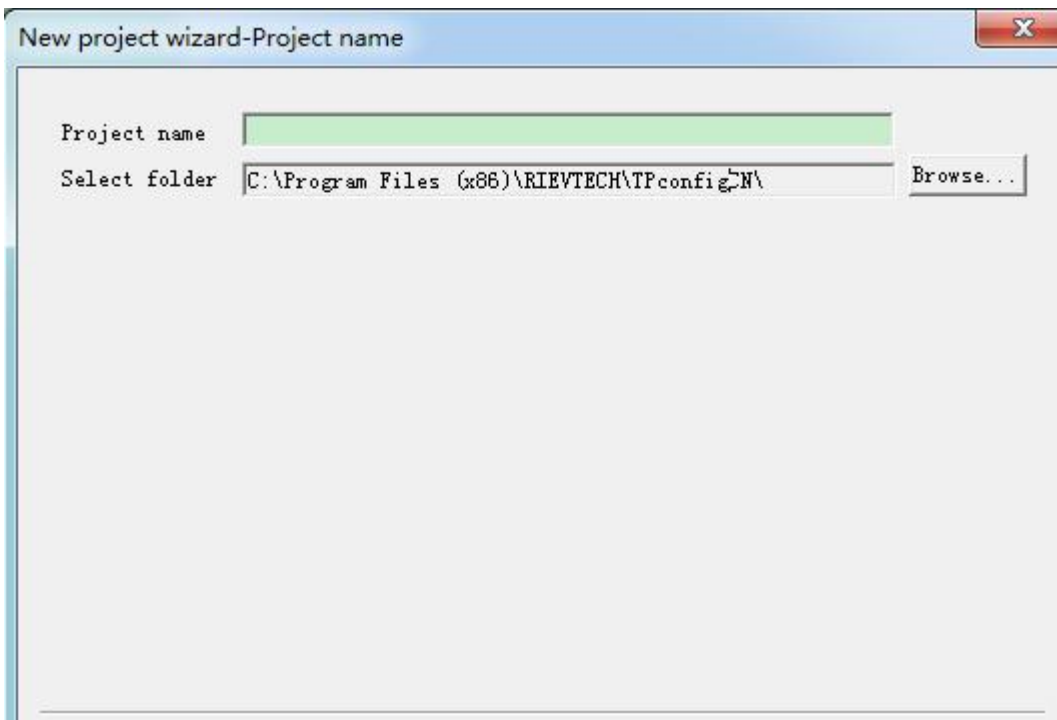

Input customized project file name in this window and choose file storage location, then press "Next", the following dialogue will be pop up for us to choose the right model.

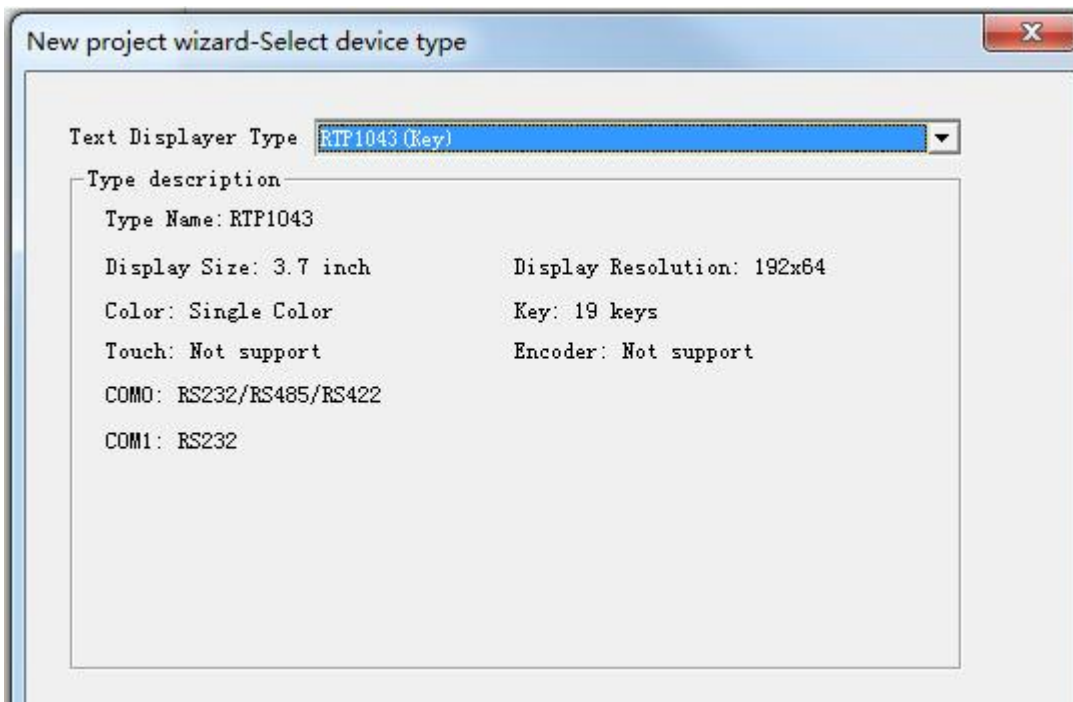

If "Next" is clicked , it will enter the needed connecting controller window, including setting up various communication parameters. If "Finish" is clicked, the system defaults that no need setting up the

needed connecting device. Select the PLC type according to the object that is connected with RTP1043.

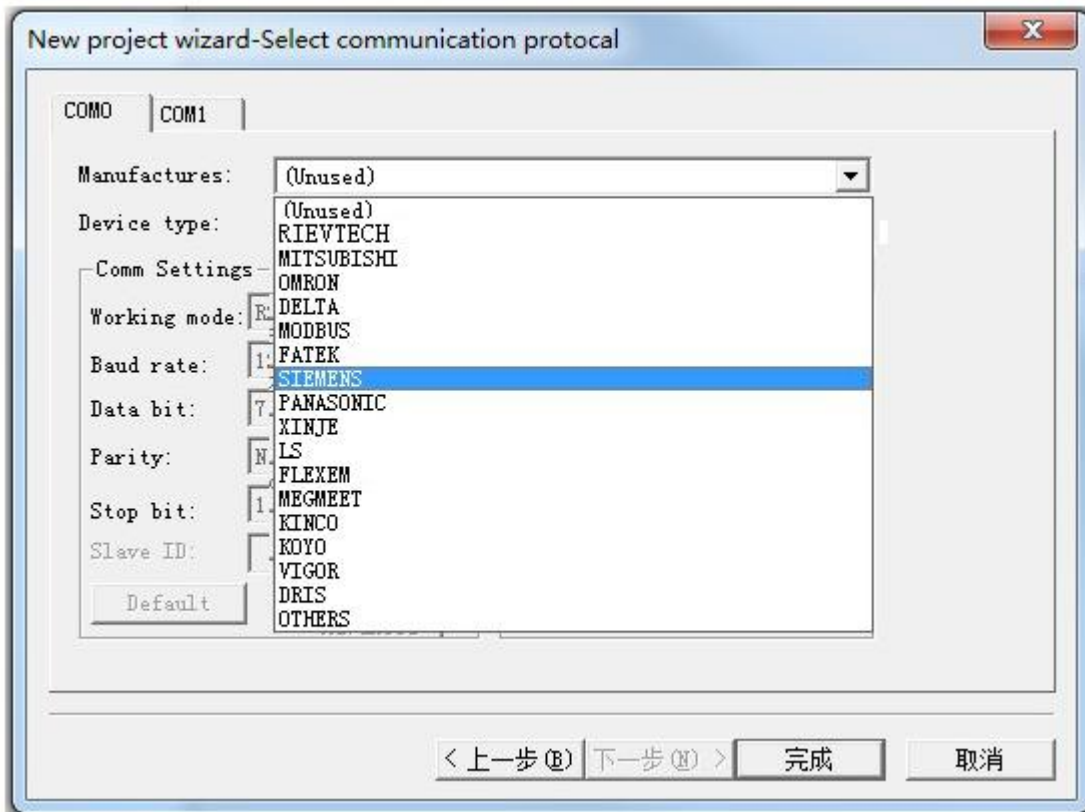

After setting up the connecting PLC, click “Finish” button, then click “Yes”, then the new project will be finished and it will enter the picture editing status. Click “No” button, then the right text displayer model and needed connecting PLC model will be chosen again through clicking “Last Step”.

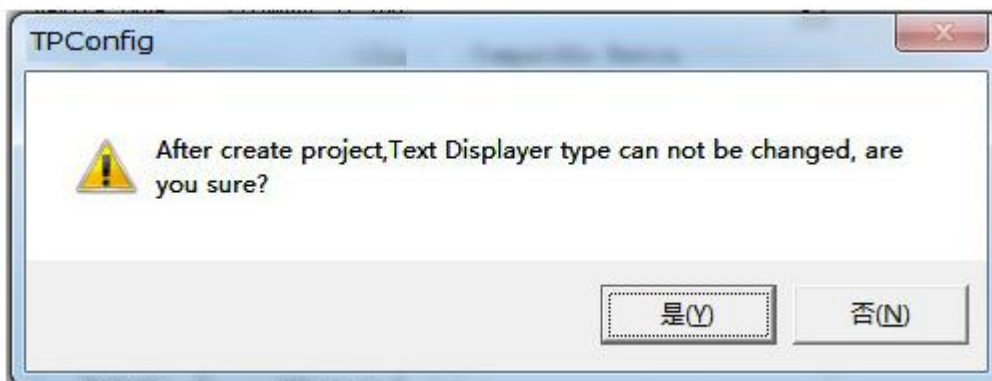

The window data and the protocol corresponding to the selected PLC will be downloaded to RTP1043 text displayer when executing the window downloading function of TPConfig. RTP1043 will communicate with PLC after the protocol loaded.

### 2.2.2 Making Basic Window

In the example given below, the PLC type is Mitsubishi FX series. The example will give you a general description of window making.

Firstly, enter the system initial window (default value is window no.1) editing mode. The properties of the current window (window no.1) are shown at the right and bottom edge of the interface. Every window

has its own properties, including three items:

- **Window Description:**  
Describe the use of the window. It helps the designer to note the use of all the windows. (can be omitted),for example:“main menu”
- **When Up Arrow key ([▲]) pressed, jump to window:**  
The number of the window that it will jump to when Up Arrow key pressed.
- **When Down Arrow key ([▼]) pressed, jump to window:**  
The number of the window that it will jump to when Down Arrow key pressed.

The most convenient way for window jumping is to press [ESC], [▲] and [▼] when RTP1043 is running. The user can also jump from one window to another by pressing the user-defined function keys.

**Note:**

- If the [▲] and [▼] key in the current window are defined for other functions, the window jumping parameters of the window properties are invalid.
- If the window designated by the [▲] or [▼]key doesn't exist, the system will search up until the existing window is found and jump to it. It will stop at window 1 if no window is found. The situation of the [▼] key is similar, that means the system will search down for the window if the designated one doesn't exist..
- If there are some data setting components in the window, [▲] and [▼] key will execute the function of value increase and decrease in the data setting mode. After quitting the data setting mode, the [▲] and [▼] key will execute the basic function for window jumping.

### 2.2.3 Configuration of RTP1043

Press  or activate [Tools]->[RTP1043 config] command to pop up a dialog box for configuring the system parameters of RTP1043:

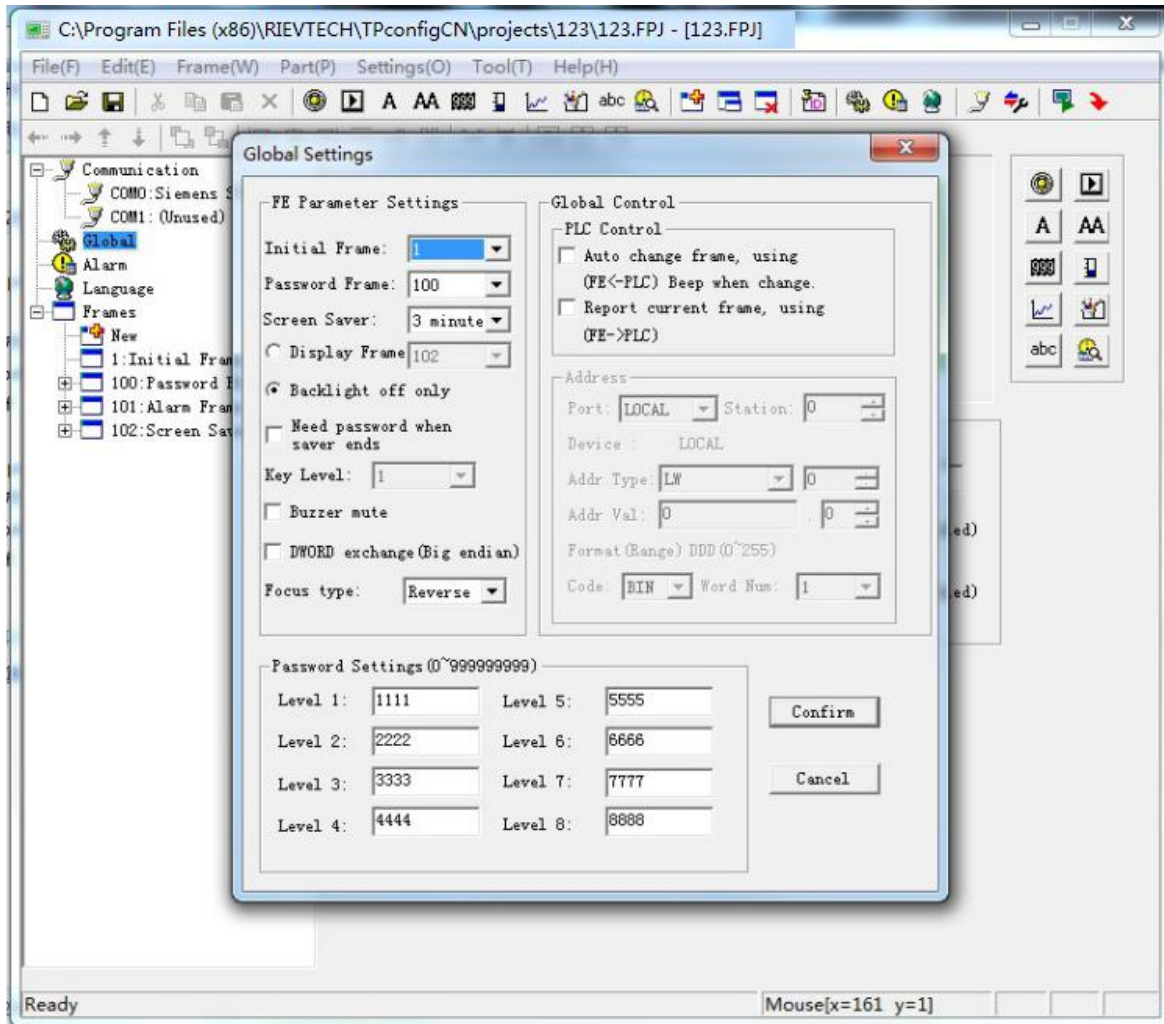

■ **Initial Window**

The first window will be displayed after power on. Usually this window is set to be the main menu window or the most-frequently-used window.

■ **Password**

All the windows of a project share a common password. The default password of the system is 100. When the “Password” attributes of the components such as data setting window, function keys and etc. is enabled, the components can only carry out their functions when the right system password is entered. With this function, the user can hide the windows and secure the data. The password operation is discussed in the following text.

**Note:** Password is valid only when there is a component whose password attribute is enabled in all the windows of the project. The password can be an arbitrary integer between 0 and 999999999.

■ **Screen Saver**

Under default conditions, the backlight will hold for 3 minutes. The time can be set by the user. If it is set to be “never”, the backlight will keep on. Also, the window can be set to jump to a screensaver window when no key is pressed in 3 minutes.

Displaying window: If the press is not activated/operated in setting time, the system will shift to this window automatically.

Turning off backlight only: The backlight will turn off when the setting time arrives.



Password needed when screen saver reverts: If this is chosen, the password needs input when quitting screen saver back to normal operation window. Password level is decided by setting. For instance, if the password level “1” is chosen, the password is “1111”. Then when the screen saver occurs, the screen saver window needs to be withdrawal back to normal operation window and right password “1111” needs to be input.

**Note:** If the window has jumped to a screen saver window, the pressing of any key will not carry out any function. Any operation will awake the screen saver to return to the original window. Only text or picture component can be used as screen saver. Dynamic components such as register and bar graph can't be used as screen saver.

■ **Buzzer Mute**

This item is defaulted without ticking. When the button is pressed, the buzzer will beep. If this item is ticked, the buzzer will not beep when operating text displayer.

■ **Exchanging of Double Words**

For some specific controller, the format of the double words is different from most controllers, the high-low words are conversed. If the item is ticked, the needed data can be indicated normally. For instance, the double words' data of the controller is “0x12345678”, if this item is ticked, the indicating data is 0X56781234.

■ **Focus Display**

This item defaults as “reverse color”, if “twinkle” is chosen, it will be “twinkle” effect. This effect is mainly for the operating components effect, such as the operating data register and button etc components.

■ **PLC Control**

Automatic changing of indicating window: If this item is ticked, the needed indicating windows will be changed automatically according to the set register value.

Reporting current windows: if this item is ticked, the current window NO. value will be sent to the set register.

For instance as below:

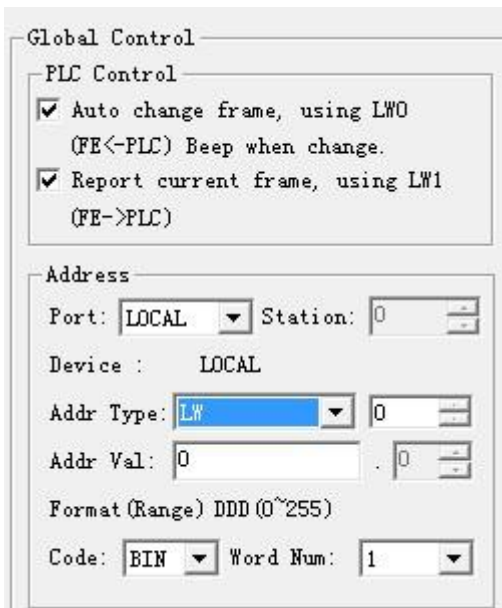

When PLC is needed to switch windows automatically, only the window NO. value is to be sent to register D0. The buzzer will make a sound when shifting windows. After windows shifting finished,













the current window NO. value will be sent to D1 register. When D0 register value is 10, the window will be shifted to NO.10 menu automatically. After shifting, 10 is valued to D1. When D0 gets one non-existed window NO, windows will not be shifted and current window will not change.

■ **Password Setting**

Different level password can be set. Password ranges from 0~999999999. Password level can be 0~8, level 0 is valid for all manipulators without any password. Level 1~8 is valid only with concerned password input.

**2.2.4 Text**

The table below describes the functions of the 10 components on the top of the window editing box:

Component	Function
	Input text, including Chinese characters or English letters or other language.
	Dynamic text list. The content of the text can be changed under the control of PLC register.
	Register components. The user can dispose some data setting/monitoring components with it. (the relate address are the PLC registers)
	LED indicator. Indicate the on/off status of the inner delays in PLC.
	Function key. The 7 keys at the lower part of RTP1043 and the other 12 keys for number input can be defined to be function keys. They can execute the functions such as window jumping and switch control.
	Bar graph. Monitor the data change in PLC in the form of bar graphs.
	Trend line. Monitor the data change in PLC in the form of trend lines.
	Paste pictures. Paste a monochrome BMP picture (Max. 192×64 pixels) onto the window.
	Indicate ASCII data of PLC register.
	Indicate incident and indicate incident date, time, fault contents etc.

The example below shows how to design a main menu window as the window no.1.

Firstly, lay the text “Main Menu”. Press  and click the left button on the editing region to affirm the operation (right click will cancel it). After left click, the default text “text” will be displayed in the editing region. The properties of the text are displayed below the editing region. The text string will move as the user moves the cursor. The distance across is a multiple of 4 points. To locate the text in an arbitrary position, edit the X and Y coordinates.

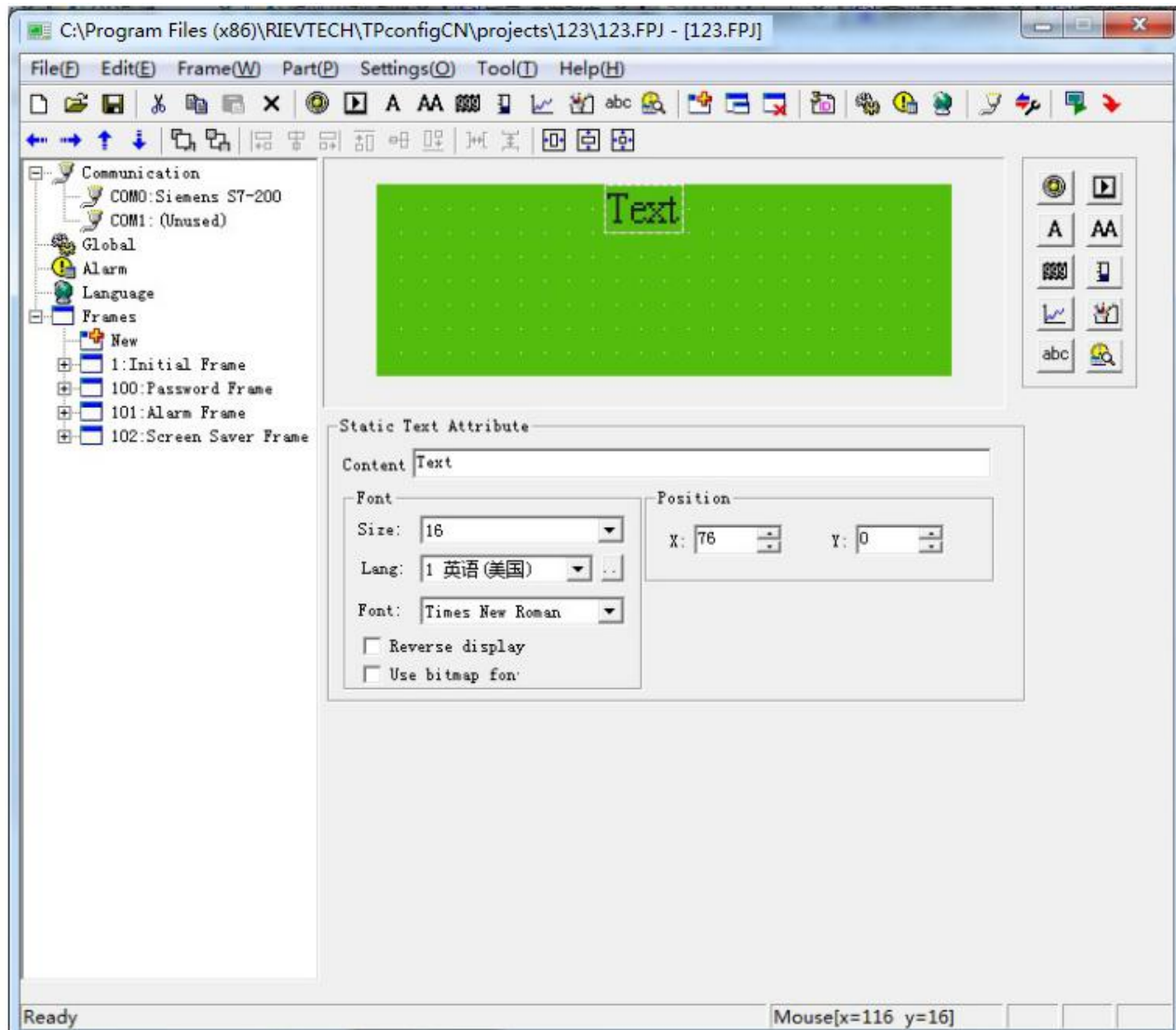

### ■ Text Strings

The content that will be actually displayed is input here. The user can input English letters or Chinese characters with various kinds of Chinese input methods in this textbox. The content in it can be cut, copied or pasted.

**Example:** Display the text “text” in reverse color. Input “text” in the text string box and select the “Reverse” checkbox.

### ■ Characters Size

Characters size can be set, the maximum is 32, for ASCII the minimum is 8.

### ■ Language

Language formats of the text can be set, such as Russia, English, Chinese etc. At most 8 kinds of languages can be set.

### ■ Character font

The character font format of the text strings can be set.

### ■ Display in reverse color

If this item is ticked, the background color of the text strings is black, otherwise there is no background color.

### ■ Position

X value represents the horizontal position of the text string.

Y value represents the vertical position of the text string.

The origin of the position is the up-left corner of the window.

For instance, “ main menu” is displayed in reverse color. The effect of offline simulation or download to the text displayer is as below:

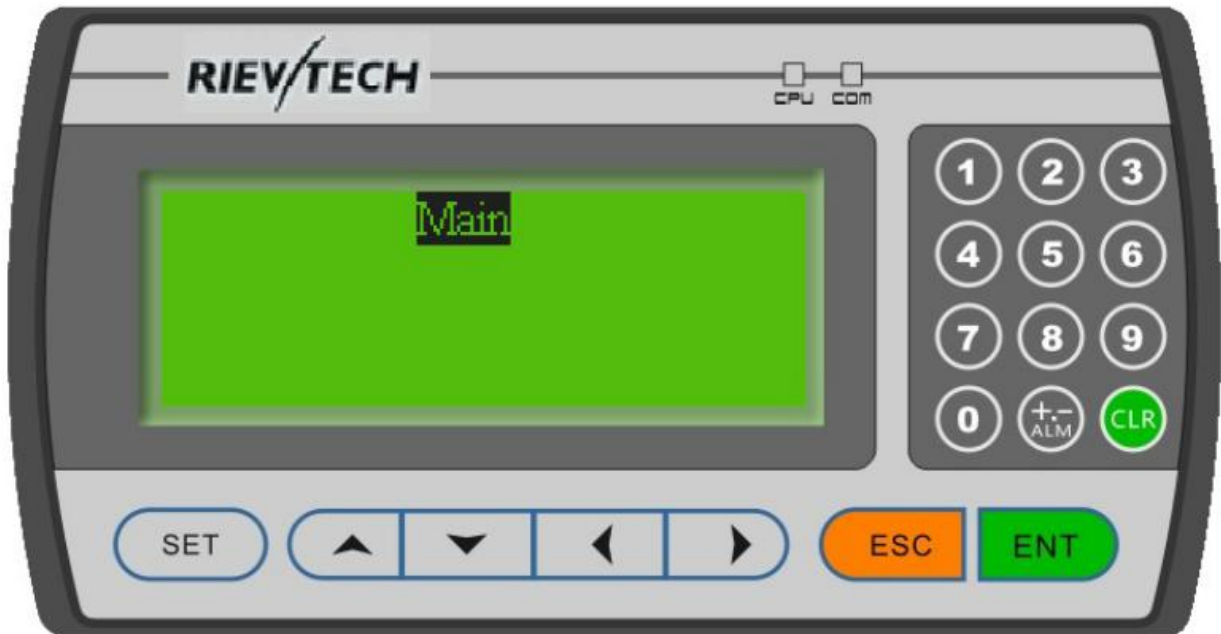

### 2.2.5 Dynamic Text

Press **AA** and click the left button on the editing region to affirm the operation (right click will cancel it). After left click, the default text “Dynamic Text” will be displayed on the editing region. The properties of the dynamic text are displayed below the editing region. The text string will move as the user moves the cursor. The distance across each time is a multiple of 4 points. To locate the dynamic text in an arbitrary position, edit the X and Y coordinates.

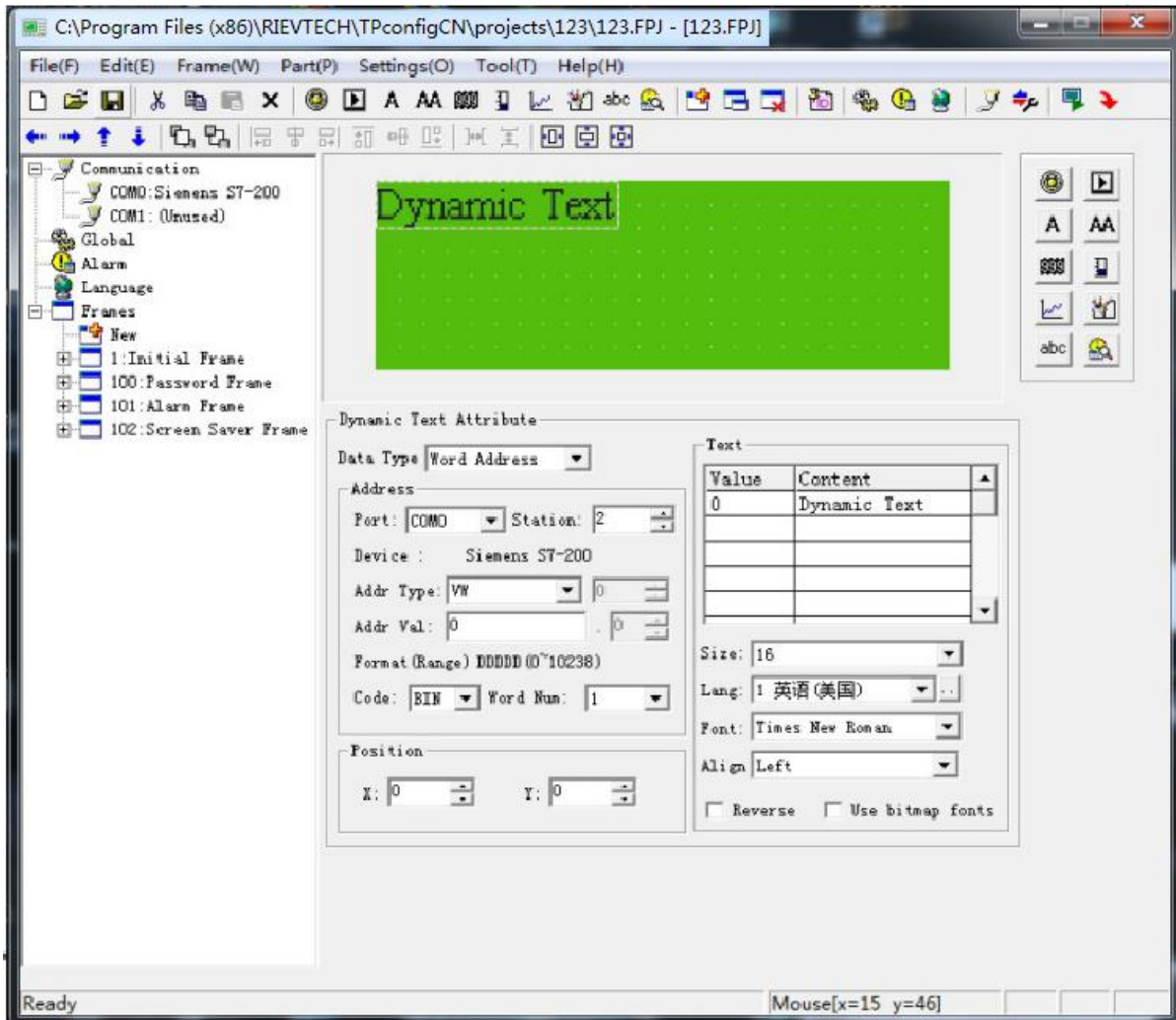

- **Position**

X value represents the horizontal position of the text.

Y value represents the vertical position of the text.

The origin of the position is at the up-left corner of the window.

- **Port**

Set which port connecting PLC to get the data.

- **Station No.**

Set the station NO. of connecting PLC.

- **Address Value**

The address of data register.

- **Coding**

BIN or BCD optional. Generally it is BIN format, which is set according to PLC register's data format.

- **Word No.**

1 or 2 is optional. "individual word" or "double word" is optional. Generally it is "individual word". If 2 is set, the low-order word is valid.

- **Register**

The PLC data register for controlling the status change of the dynamic text.

- **Mode**

Determine the data form of the data register. The form will affect the display form of the numeric items in the dynamic text.

■ **Display Text**

Log the different text contents corresponding to different values of the data register. It can keep the texts corresponding to as many as 256 different statuses. The value ranges 0~65535.

**Example:** Display the dynamic text controlled by register D0. The dynamic text to be displayed has three statuses: “Normal operation”, “Low speed” and “Position arrived”. The three texts correspond to the D0 register value 10, 123 and 6789 respectively. Input “10” in the “Value” space of the first row and “Normal operation” in the “Context” space on the right. Input the other two statuses in the same way. If the value of register D0 is 10, the dynamic text be displayed is “Normal operation”. If it is 123, “Low speed” will be displayed. Other conditions can be inferred from the two examples above. The example is shown in the figure below:

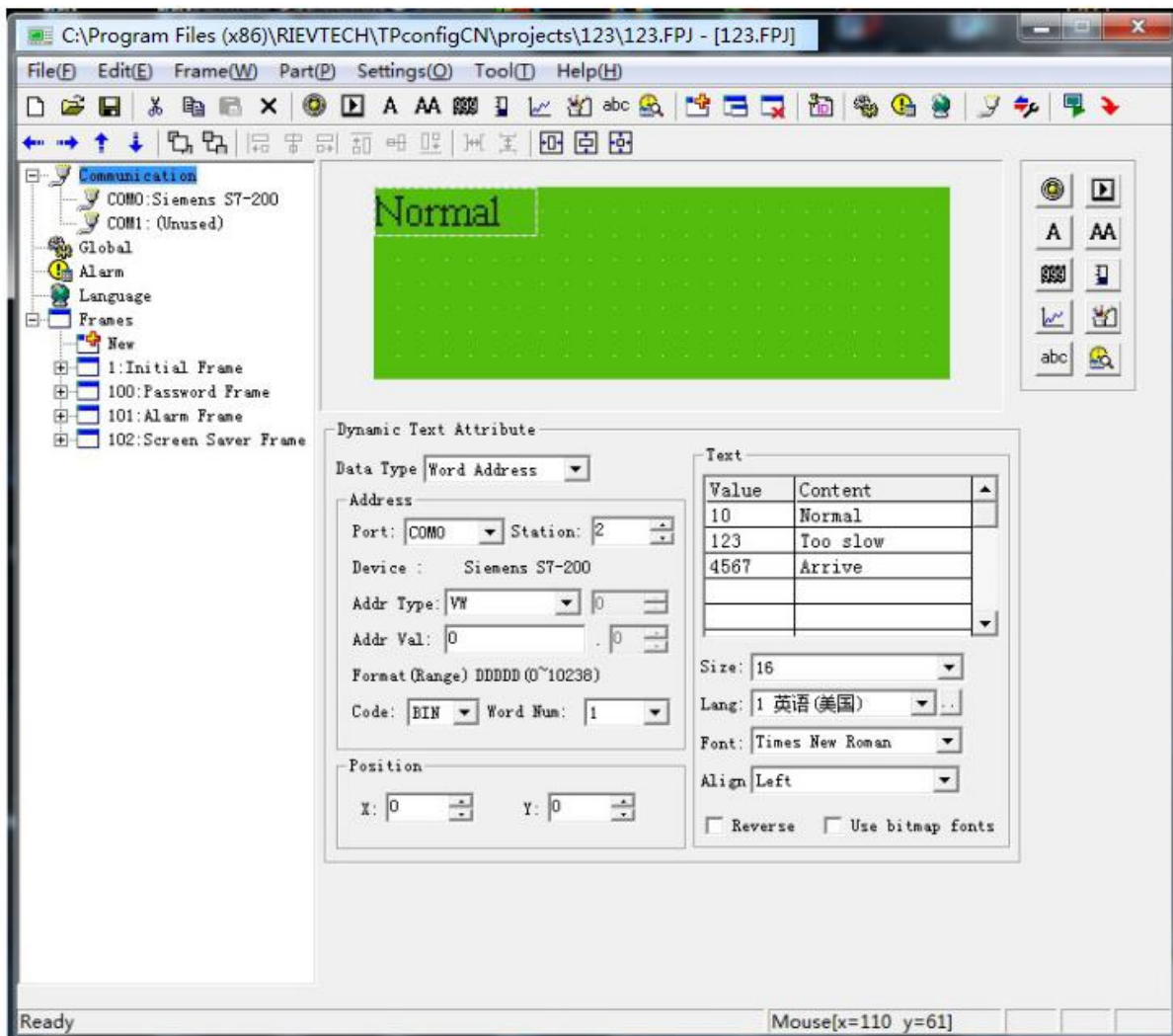

**2.2.6 Function Keys (for window jumping/characters setting/position setting)**

Next, configure the function keys in the main menu window to execute the function of window jumping (for example, press [<] to jump to the parameter setting window; press [>] to jump to the mode setting window). The procedure of defining the function keys is:



Press  to activate a dotted rectangular box. The box moves as the cursor moves. Click the left button to determine the position of the function key. A hand shape and the function key to be defined (default key is [SET]) are displayed in the editing region. The properties of the function key are displayed below the editing region. The meanings of position and style are the same as those in the text property. They indicate the position, the size and the color of the graph.

The function key setting window is shown in the figure below:

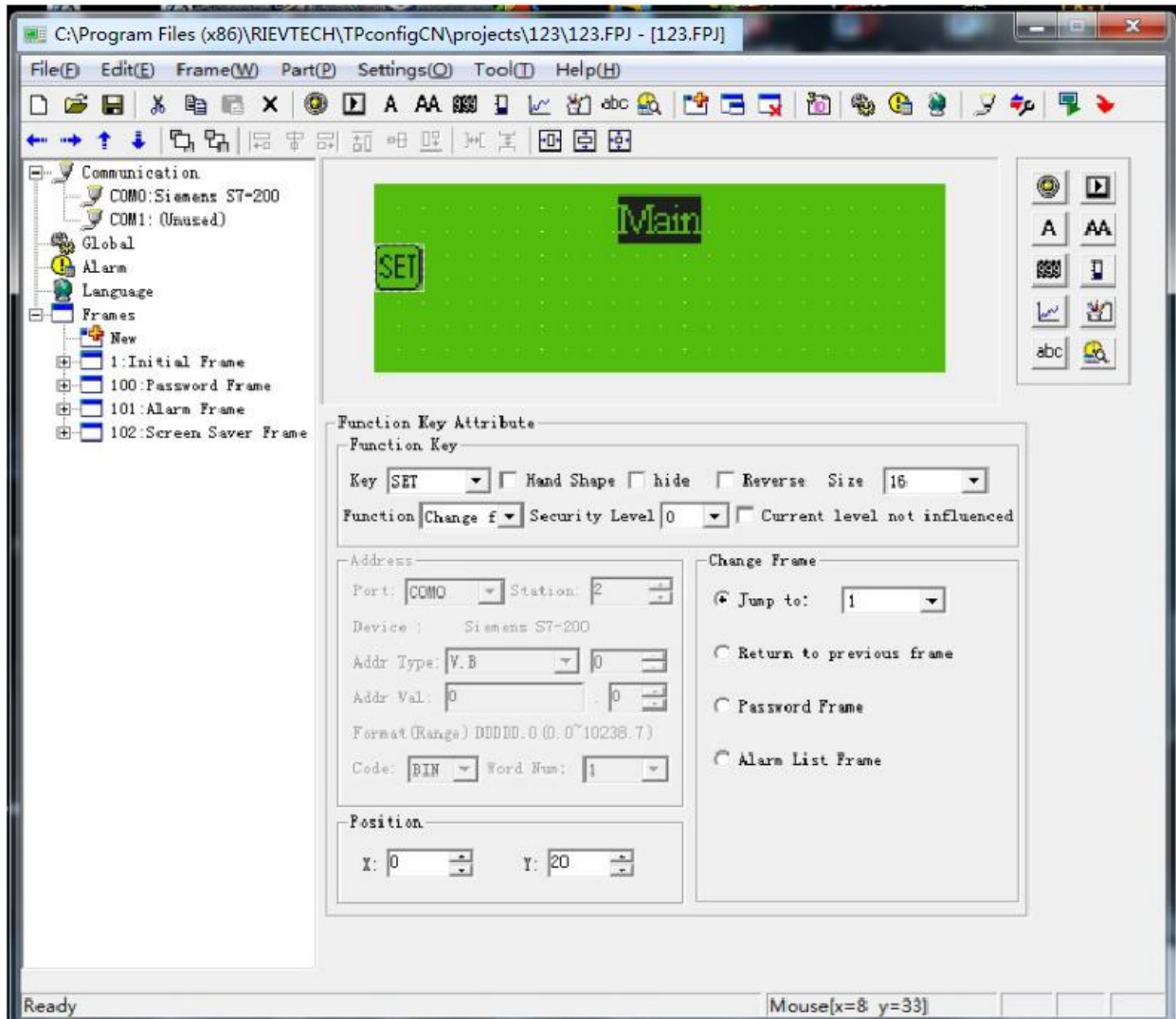

- **Key**  
Select a proper key from the 19 keys.
- **Hand**  
For the convenience of use, add a hand shape symbol before the key symbol. The hand indicates that pressing the key will carry out an operation. The user can remove the hand shape to save the space.
- **Password**  
Only when the system password is entered correctly, the function key can execute its function
- **Windows Jumping**  
The key is defined to execute the window jumping function.

#### ■ Set the Addr

The action of this function key is setting of switching value. In “Address” properties bar, set the needed address. The setting patterns are as below:

**ON:** Set the designated relay on.

**OFF:** Set the designated relay off.

**Reverse:** Set the designated relay to be of negative logic. “Position switch”: press it will be ON, press again will be OFF, then press will be ON, again will be OFF.....

**Reset Switch:** The designated relay is ON when the button is pressed. The designated relay is OFF when the button is bounced.

**Set Entering Window “ON”:** No need pressing any button, and set the designated relay ON when entering concerned window.

**Set Leaving Window “ON”:** No need pressing any button, and set the designated relay ON when leaving concerned window.

**Set Entering Window “OFF”:** No need pressing any button, and set the designated relay OFF when entering concerned window.

**Set Leaving Window “OFF”:** No need pressing any button, and set the designated relay OFF when leaving concerned window.

**Note:** Set Entering Window “ON”, Set Leaving Window “ON”, Set Entering Window “OFF”, Set Leaving Window “OFF” can set “No use” in “Key” properties.

If set M0 of PLC address “reset switch”, press button is “3”, the set window is as below:

The screenshot shows a software interface for configuring a function key. It is divided into three main sections: 'Function Key', 'Address', and 'Bit Settings'.  
 - **Function Key:** Includes a 'Key' dropdown set to '3', checkboxes for 'Hand Shape', 'hide', and 'Reverse', a 'Size' dropdown set to '16', a 'Function' dropdown set to 'Bit Sett', a 'Security Level' dropdown set to '0', and an unchecked checkbox for 'Current level not influenced'.  
 - **Address:** Includes a 'Port' dropdown set to 'COM0', a 'Station' dropdown set to '2', 'Device' text set to 'Siemens S7-200', an 'Addr Type' dropdown set to 'V.B', an 'Addr Val' input field set to '0', a 'Format (Range)' text set to 'DDDDD.0 (0.0~10238.7)', a 'Code' dropdown set to 'BIN', and a 'Word Num' dropdown set to '1'.  
 - **Bit Settings:** Includes a 'Function' dropdown set to 'Reset'.

### ■ Characters Setting

The action of this function key is setting designated register parameters. Simultaneously, set the needed register in the “Address” properties. Following properties:

**Parameters setting:** Set one parameter to designated register.

**Add:** When press it, the setting addend will be added to the designated register until it arrives the setting toplimit.

**Subtract:** When press it, the setting subtrahend will be subtracted from the designated register until it arrives the setting lower limit.

**Progressively increase:** Press the button then hold down to move the designated addend to the designated register according to the setting “execution speed”, until it arrives the setting toplimit.

**Progressively decrease:** Press the button then hold down to move the designated subtrahend subtracted from the designated register according to the setting “execution speed”, until it arrives the setting lower limit.

**Add (to limited circulation):** Different from “Add” properties, when it add to the toplimit, press it again it will become 0. It circulates in this way.

**Progressively increase (to limited circulation):** Different from “Progressively increase” properties, when it add to the toplimit, press it again it will become 0. It circulates in this way.

**Setting when entering the window:** No need press any button. The designated parameters are set to the designated register when entering the window.

**Setting when leaving the window:** No need press any button. The designated parameters are set to the designated register when leaving the window.

**Note:** When choosing “setting when entering the window” and “ setting when leaving the window” properties, the “ key” properties can be set as “no use” because of no need any buttons operation. For example, COM0 connecting PLC of D0 register, when pressing “9” then add to 10, the toplimit is 1000, the setting window is as below:



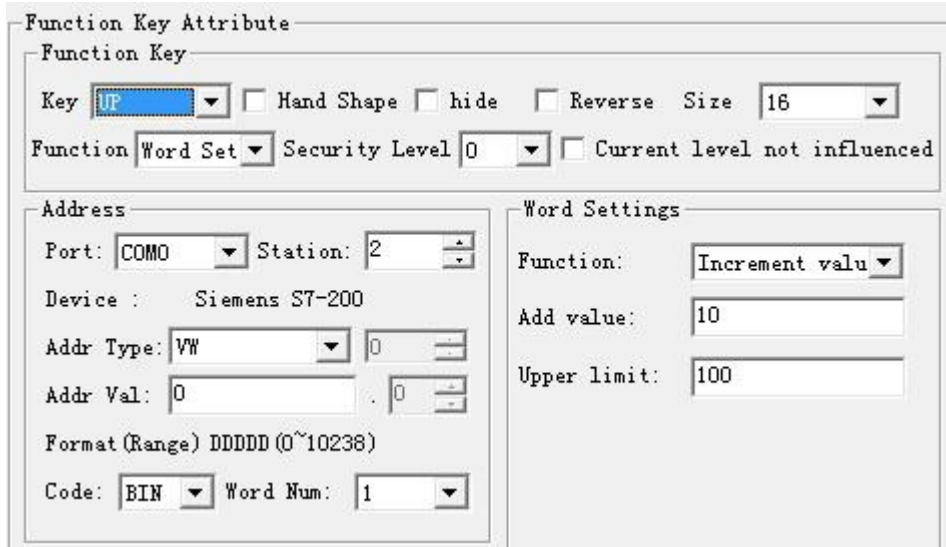

■ **Station No.**

The station number of PLC

**Summarization:** Through above illustration, following functions can be realized by using function key:

1. Jump to the designated window.
2. Change the designated position status.
3. Change the designated register parameters, and no need pressing any button when entering or leaving the window. Change the designated position status or set one initial value for designated register etc.

**2.2.7 Data Display**

This section will introduce how to make a *Set parameter* window. The methods of setting the components such as parameter display, parameter setting and password setting are discussed.

**Example:** The window no.10 sets and monitors three couples of parameters, which are corresponding to the output of group A, B and C respectively. The current values are in the left column, while the target values in the right one. The current values can be used to monitor the data only, while the target values can be used for both monitoring and changing the data. The relation between the parameters and the PLC data registers are given in the table below:

	Addr. of the current values	Addr. of the target values
Output of Grp.A	D100	D110
Output of Grp.B	D101	D111
Output of Grp.C	D102	D112

The procedure of making the window:

Click [New] to pop up a dialog box for setting the window number and the window description.



■ **Window No.**

The serial number of the new window.

■ **Window Description**

Describe the character of the new window.

Set the window number to be 10 and input the window description “Set parameter”.

Click [OK]. The window properties are displayed at the right and bottom edge of the interface. Set the destination window number of [▲] to be 1 and that of [▼] to be 20. So when it is not in the data setting mode, it will jump to *Main Menu* if [▲] is pressed and to *Set parameter* if [▼] is pressed.

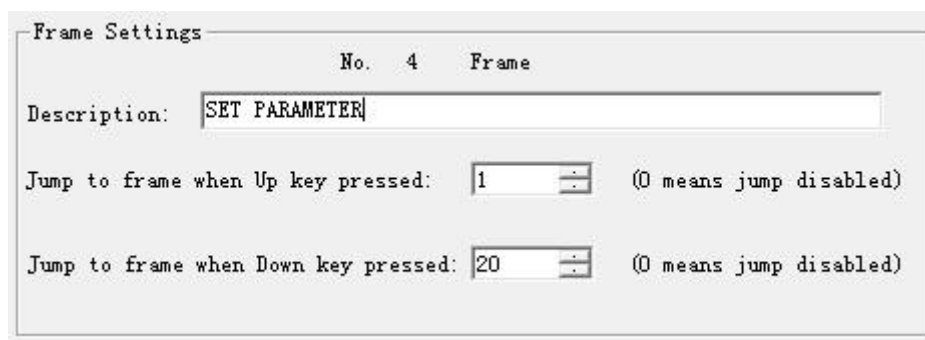

Put the text “Current”, “Target”, “A Output=”, “B Output=” and “C Output=” in proper positions in the editing region.

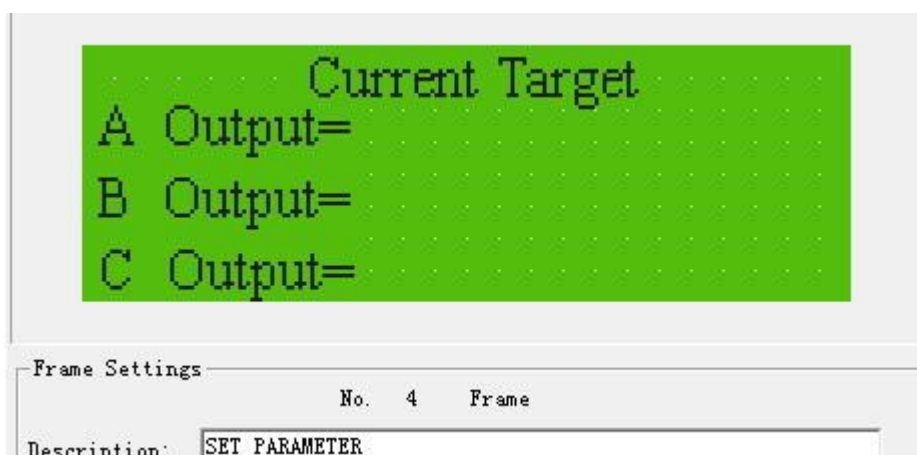

Put the data display boxes. Press  to show a rectangular dotted box moving with the cursor. Click the left button in the proper position.

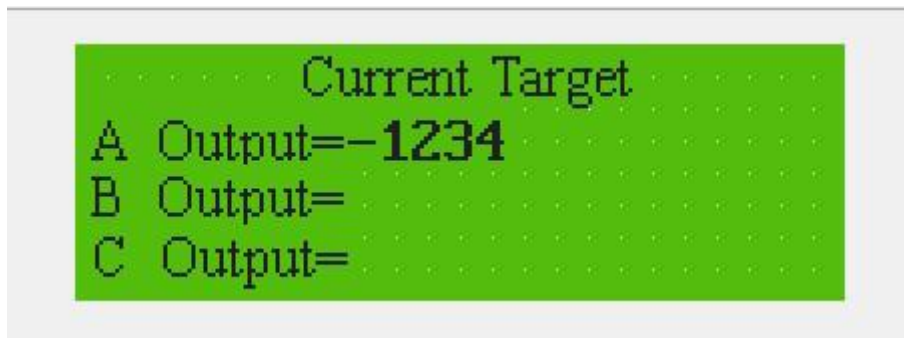

The number “12345” in the dotted box indicates that this component is a five-digits register displaying/setting box. The properties in the dialog box are:

- **Style of the Register**

It indicates the needed display data type. There are mainly following data types:

10 decimal signed number: including 16 signed number and 32 signed number.

10 decimal unsigned number: including 16 unsigned number and 32 unsigned number

Hexadecimal/BCD: Data will be indicated as hexadecimal format.

Single precision floating point number: Data will be indicated as single precision floating point number format.

Double precision floating point number: Data will be indicated as double precision floating point number format.

Password: Indicate the data as \* format, password format.

- **Digits**

Single digit: one 16 bit register.

Double digits: two 16 bit registers.

- **Integer Bit**

Indicate or set the data digits of integer bits.

- **Decimal**

Preserve valid data digits after decimal points.

- **Alignment**

Set the alignment way of the data, left justifying, right justifying and align centering can be chosen.

- **Station**

The definition number of the PLC register is corresponding to the display component.

- **Leading 0**

If selected, when the data digits are less than the setting integer digits, the front is filled with 0.

- **Reversion**

If selected, the data is displayed with “black color” as bottom color.

- **Coding**

BIN or BCD is optional, generally it defaults as BIN. It is influenced by PLC data type.

- **Set**

The component can be used for setting data if it is selected. So the component can be used for

both monitoring and setting the data. The register set box has some special properties: maximum, minimum and password.

In this example, the settings are listed below:

Register type=D; Addr=100; Register=1; Digits=5; Decimal=0; Decimal digits displaying; the negative number will not be displayed.

The screenshot shows a configuration window with the following sections:

- Register:** Type: Signed Decimal, Data Width: Word, Leading 0: , Reverse: . Interger: 5, Decimal: 0, Size: 16, Align: Right.
- Address:** Port: COM0, Station: 0, Device: Mitsubishi, Addr Type: D, Addr Val: 100, Format (Range) DDDD (0~7999), Code: BIN, Word Num: 1.
- Position:** X: 40, Y: 28.
- Settings:**
  - Enable Set Security Level 0
  - Current level not influenced
  - Input limit
  - Min value: 0, Max value: 9999
  - Use scale conversion
  - Min value: 0, Max value: 9999

Set the display boxes of the current output of group B and C in the same way. The register addresses are D101 and D102. The other properties are the same as those of group A.

### 2.2.8 Data Setting

Continue the configuration of the parameter-setting window. Press  to show a dotted box moving with the cursor. Move the cursor until the proper position is reached, then click the left button to confirm the position. Select the "Set" checkbox. So the component has the function of monitoring and setting the data.

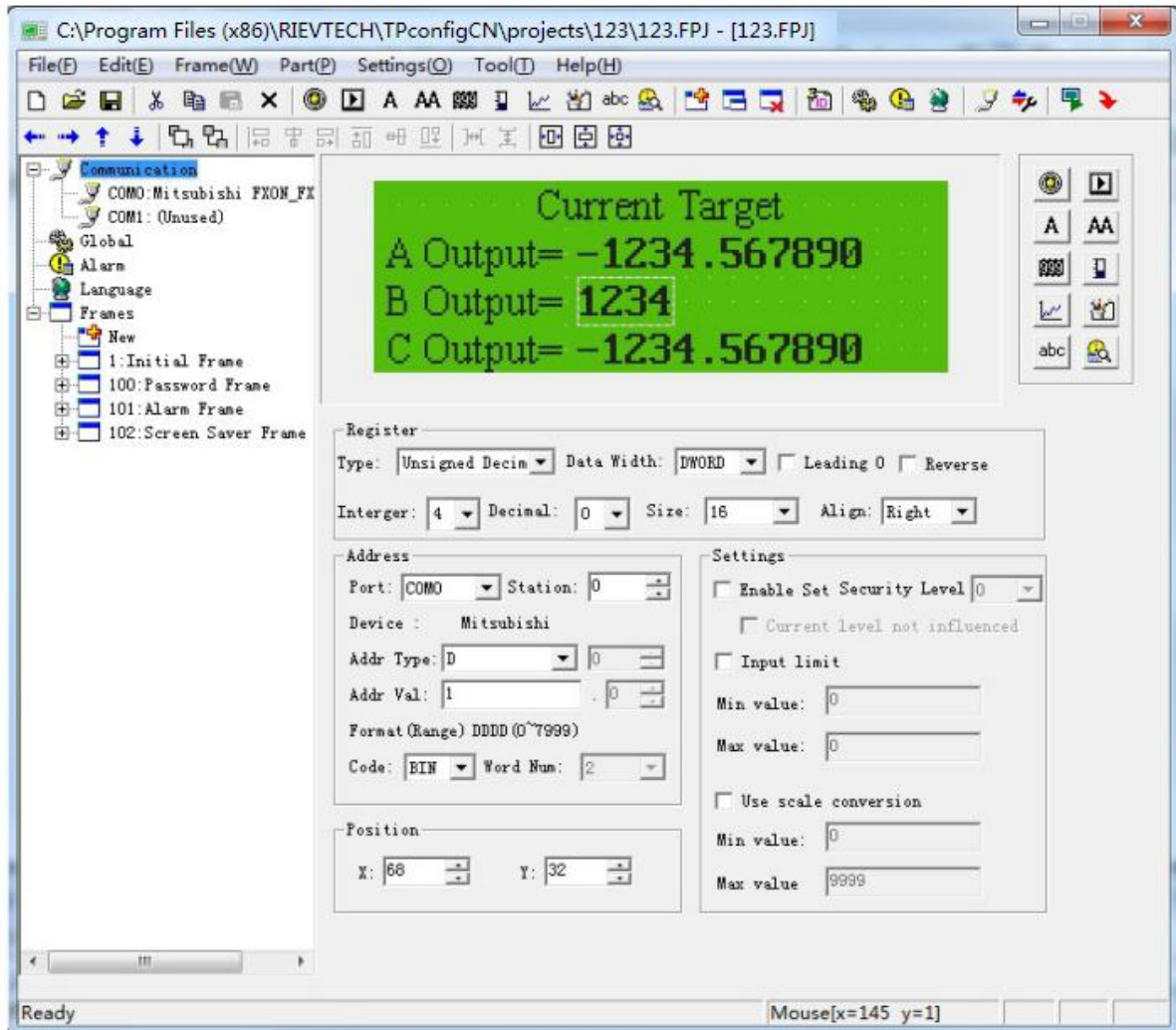

- If the “Set” checkbox is selected, three additional options, “Password”, “Original and Project data” and “Limited”, are enabled.
- **Password**  
To enhance the security of the device, the operation of parameter setting can be protected by password.  
0~8 password levels is available for the whole project, and it defaults as 0, no need entering any password. When setting any password between 0~8 levels, then the operation is valid when inputting according password under windows.  
The data can be changed only when the operator enter the correct password. All the windows of one project share a common password.
- **Limited**  
The designer can set limits to the data to make the data out of limits invalid. Thus the possible damage done by inputting data too great or tiny is avoided. For example, let the maximum input be 9000 and the minimum be 0. The setting value will be written into the register only when it is between 0 and 9000, or the system will halt until a correct value is entered.

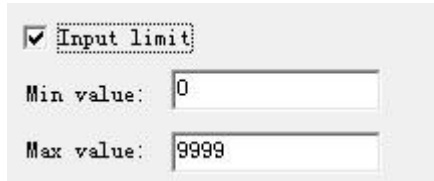

■ **Original and Project data**

After selecting the “Limited” checkbox, the designer can select the original data or the project data from the list.

**Original data**

The original data option means that the data in the register will be displayed without any operation. The position of the decimal point is determined by the value of the “Decimal” property.

For example, if “Decimal”=2 and the register value is 14561, it will be displayed as 145.61.

**Project data**

This option means that the data read from the register will be converted to project data before being displayed. The conversion is done following the formula below:

The Converted Data= Eng. Min + (original register data – Min Input) \* (Eng. Max – Eng. Min) / (Max Input – Min Input)

For instance, the data stored in the register is the binary output of a 12-digits A/D, while the data being actually displayed is a voltage between –10000mV and 10000 mV. Do the setting like this:

- Max Input: 4095
- Min Input: 0
- Eng. Max: 10000
- Eng. Min: -10000

In this way, the result of A/D conversion in the register is displayed as the voltage value.

**Note:** Because of the limited accuracy of floating point operation, there may be some errors in the conversion result.

■ **Engineering Limits**

The maximum and minimum of the project data

**2.2.9 LED**

The procedure for making the *Set status* window and the method of setting LED and function keys are introduced in detail in this section.

**Example:** the window no.20 is the window for setting the working mode of the machine: manual or automatic. In manual mode, the direction of the movement of the machine (forward or backward) is controlled by pressing the keys on the front panel. The LED indicates the direction of rolling. The relation between the relay statuses and the actions is listed in the following table:

Relay status	action
M10=1	Manual mode
M10=0	Automatic mode
M20=1	Move forward
M21=1	Move backward
M20=0 , M21=0	stop

The procedure of window is given below:

Press [New window] to pop up the dialog box of window number and window description. Set the window number to be 20 and input the window description *Set status*

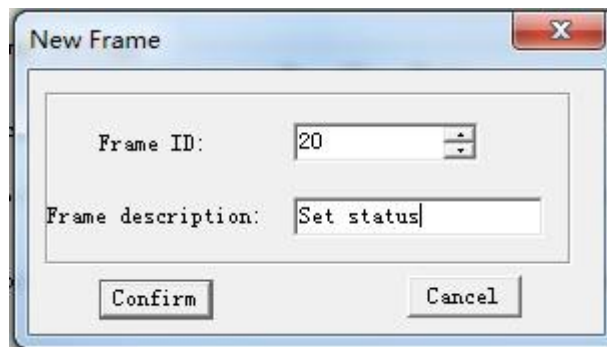

Click [Ok]. The window properties are displayed at the right and bottom edge of the interface. Set the destination window number of [▲] to be 0 and that of [▼] to be 10. So when it is running, it will jump to *Main Menu* if [▲] is pressed and to *Set status* if [▼] is pressed.

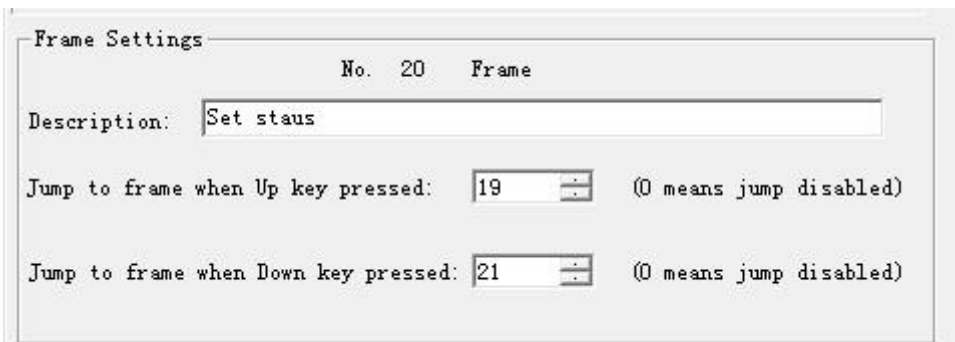

Press  to put a LED. There is a dotted box moving with the cursor in the editing region. Click the left button in the proper position to locate the LED.

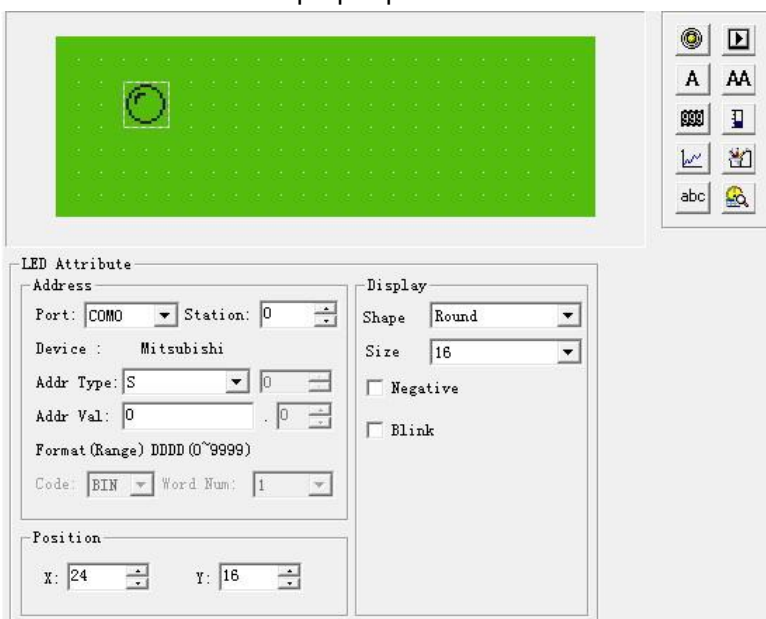

The definition number of the coil shows the PLC switch address corresponding to the LED

Two kinds of LEDs: round and square

Positive/Negative Logic indicates that the LED is on/off for the TRUE status



- **Coil Station No.**  
The definition of the PLC intermediate relay that is corresponding to the LED
- **Shape**  
The shape of the LED, round and square.
- **Positive Logic**  
The LED is filled when the corresponding intermediate relay is ON. Unfilled when the corresponding intermediate relay is OFF.
- **Negative Logic**  
The LED is unfilled when the corresponding relay is ON. Filled when is OFF.
- **Twinkle**  
Optional item. If clicked, “ status 0 twinkle” or status 1 twinkle” , and twinkle frequency can be chosen from 0.1S~10S.

Set the coil station No. to be M10; select square shape; select positive logic.  
There is an unfilled square LED in the editing region.

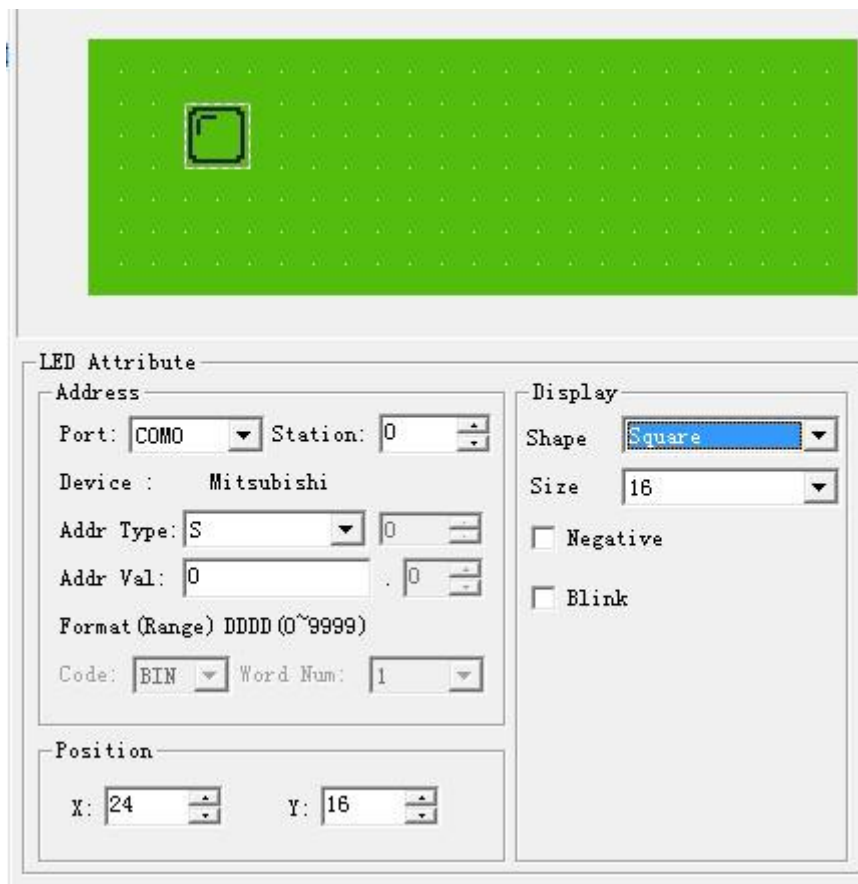

Press  to put the function key. There is a dotted box that moves with the cursor in the editing region.  
Move the cursor and click the left button in the proper position to locate the key.



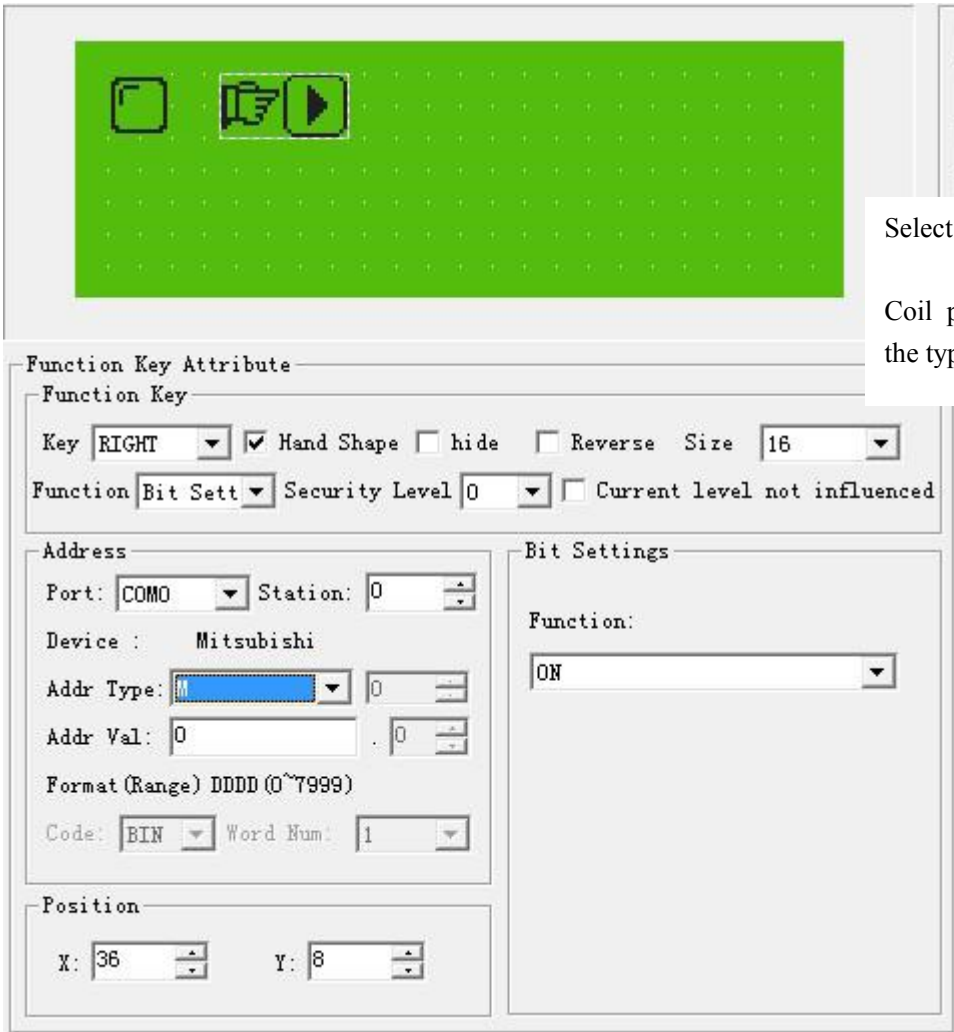

Select [SET] to be the key for setting the *Auto Mode*. Set the type and station No. to be M0; select "ON" as the type of key action; remove the hand shape to make the window simple.

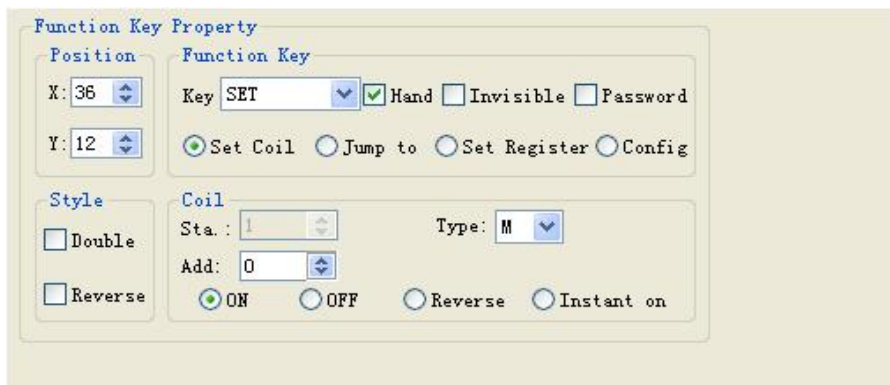

Put the text "Auto" to the right of the key to indicate that the function for this key is to select the auto mode.





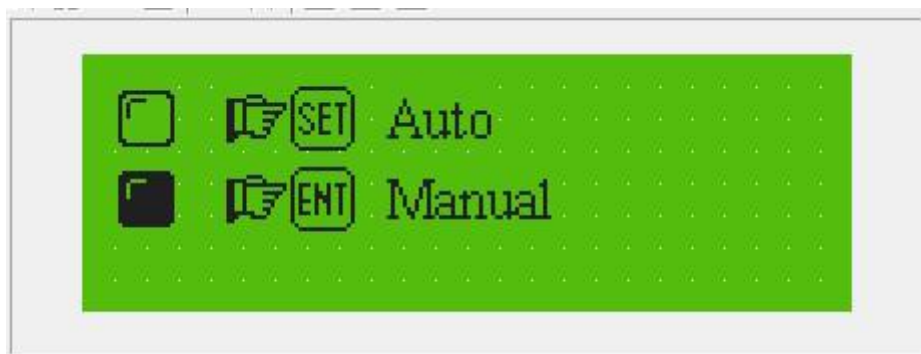

Set the *Manual* key and the *Manual mode* LED in the same way. The corresponding address of the LED is still M0; select negative logic in the display column. The designated key is [ENT], whose function is to set the relay M0 OFF.

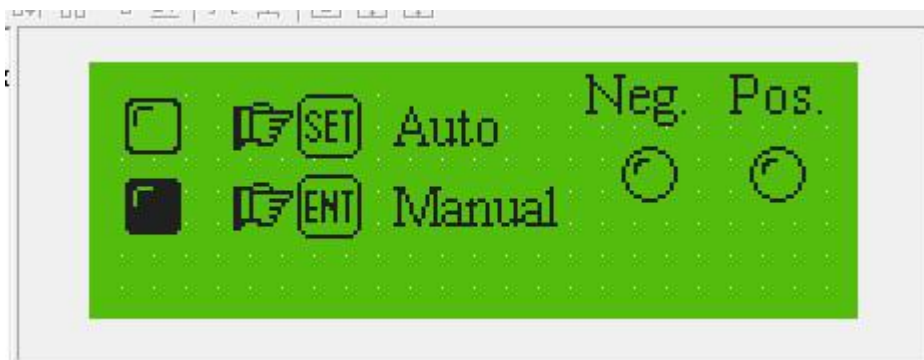

Add two round LEDs of positive logic to monitor the moving status of the machine. The addresses of the two LEDs are M20 and M21. The left one is on when the machine is moving forward, while the right one is on when it is moving backward.





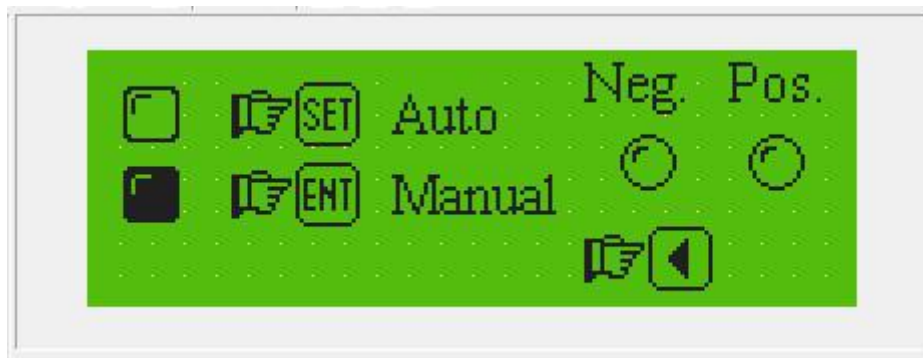

### 2.2.10 Function Keys (for controlling the status switches)

Press  to put the function key. Select , whose corresponding address is M20. the function of the key  is to set the relay M20 ON instantly. Retain the hand shape on the window. When  is pressed, the M20 relay of the PLC will be set ON, and the machine begins to move forward (program the PLC to designate M20 relay as the trigger of Y0); when  is released, the M20 relay of PLC will

return to OFF, and the machine stop the forward movement.



Press . Select , whose corresponding address is M21. The function of  is to set the relay M21 OFF instantly. Retain the hand shape on the screen. When  is pressed, the relay M21 of PLC is set ON, and the machine will begin to move backward (program PLC to designate the relay M21 as the trigger of Y1); when  is released, the relay M21 returns to OFF, and the machine will stop its backward movement. Put the text "Pos." and "Neg." to indicate the forwardness and backwardness of the movements.

### 2.2.11 Bar Graph

The bar graph can give a direct view of some analog parameters such as flow rate, pressure and level. The user can set the height, width and the direction of it arbitrarily.

Press  to show a dotted box that moves with the cursor. Move the cursor to the proper position and click the left button to locate the bar graph there.

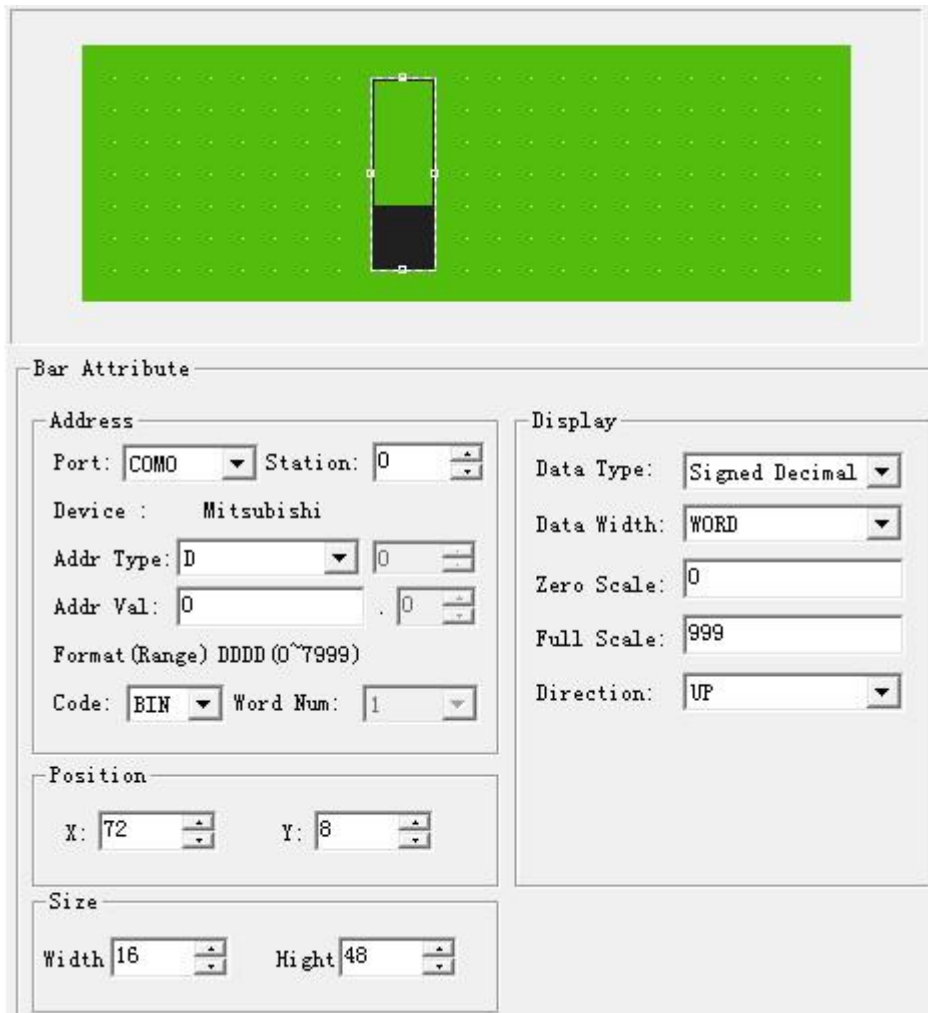

- **Register Address**

The address of the PLC register is corresponding to the bar graph

- **Indication**

Data type: The data format of the register, as numerical elements, decimal signed number, decimal unsigned number, hexadecimal/BCD, single precision floating point and double precision floating point etc format.

Width of data: Single word or double word is optional.

0 limit value: The indicating value of register when bar graph 0% scale indicates.

Full limit value: The indicating value of register when bar graph 100% scale indicates.

Draw direction: [▲], [▼], [◀], [▶] can be optional.

- **Direction**

The direction of the bar graph, including four options: up, down, left and right.

■ **Size**

The height and width of the bar graph

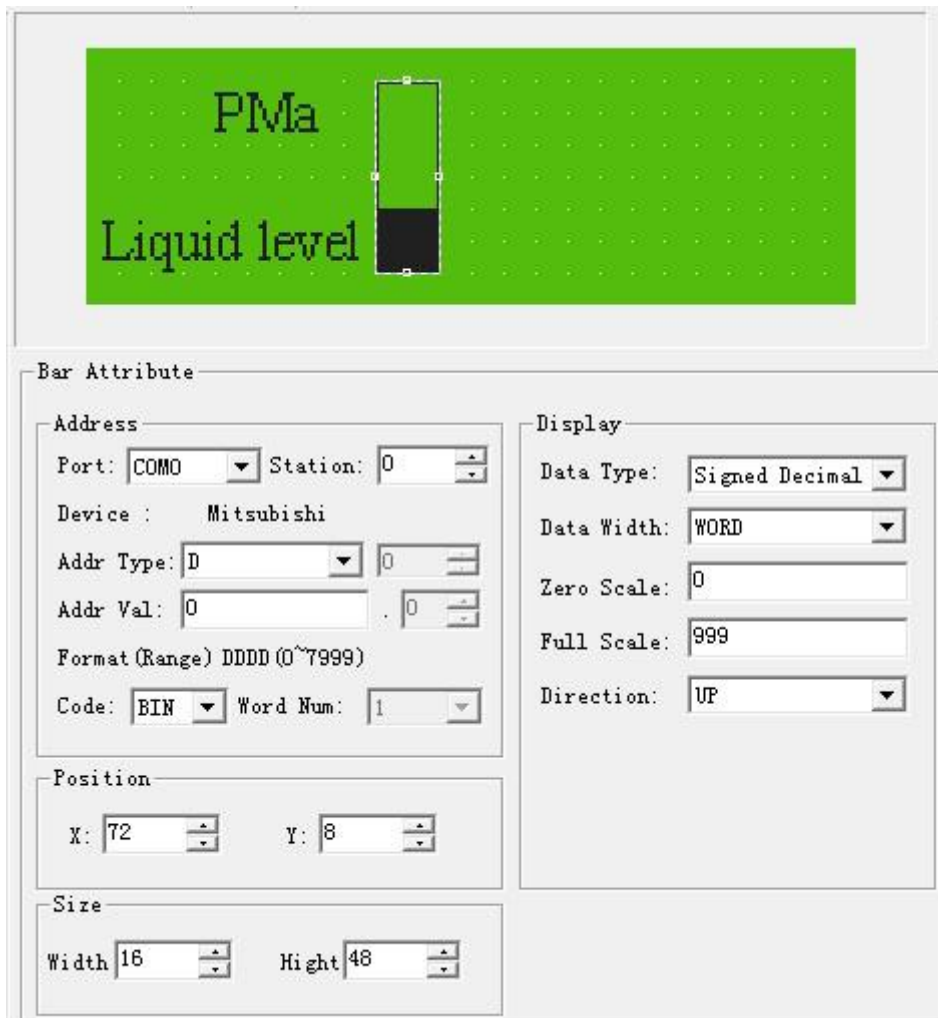

This bar graph can be used to monitor the data in register D300. The bar graph is full when the value of D300 is 100. When the bar is filled 50%, the value of D300 is 50.

**2.2.12 Trend Line**

Some parameters in industrial control applications vary at a slow rate. Often, the operators want to know the variations of these parameters in a certain time. Trend line should be the best choice.

Press  to show a dotted box that moves with the cursor. Move the cursor to the proper position and click the left button to locate the trend line there.

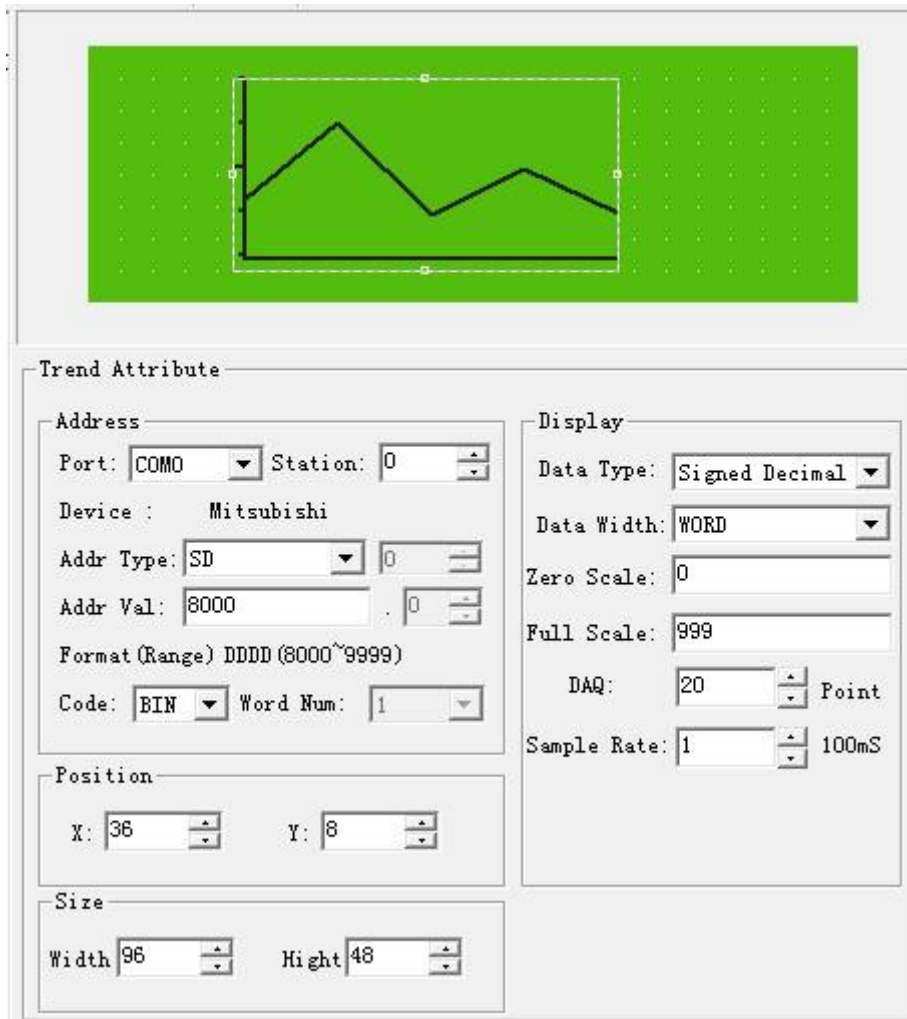

■ **Register Address**

The address of the register corresponding to the trend line

■ **Indication**

**Data type:** the data format of the register, same as numerical value, there are decimal signed number, decimal unsigned number, hexadecimal/BCD, single precision floating point and double precision floating point etc format.

**Width of data:** Single word or double word is optional.

**0 limit value:** The indicating value of register when bar graph 0% scale indicates.

**Full limit value:** The indicating value of register when bar graph 100% scale indicates.

**Data Sample (number of dots)**

The total of the sample points in the whole trend line. The more sample dots does the trend line has, the more detail it can provide. Certainly more sample dots make the time period longer.

**Sample Interval:**The interval between two sample points, minimum value is 0.1S.

■ **Location**

The coordinate position of the trend line graph in the windows.

■ **Size**

The length and width of the trend line

**Note:** A trend line component can display only one line.

### 2.2.13 Alarm List

In industrial auto-control applications, alarming is a very important function. It can be used in many cases. Alarm list is the most direct and simple method.

Every project of TPConfig can have a cluster of alarm list information. Every piece of information corresponds to a relay. The addresses of all the relays are continuous. The user can designate the initial address of the relays. When any of the relays jumps from OFF to ON, the corresponding alarm information is activated. If another relay jumps to ON, the new information will be displayed in the second row. When some alarm relay jumps to OFF, the corresponding alarm information will disappear automatically.

To log the alarm information, press  to pop up the alarm list dialog box:

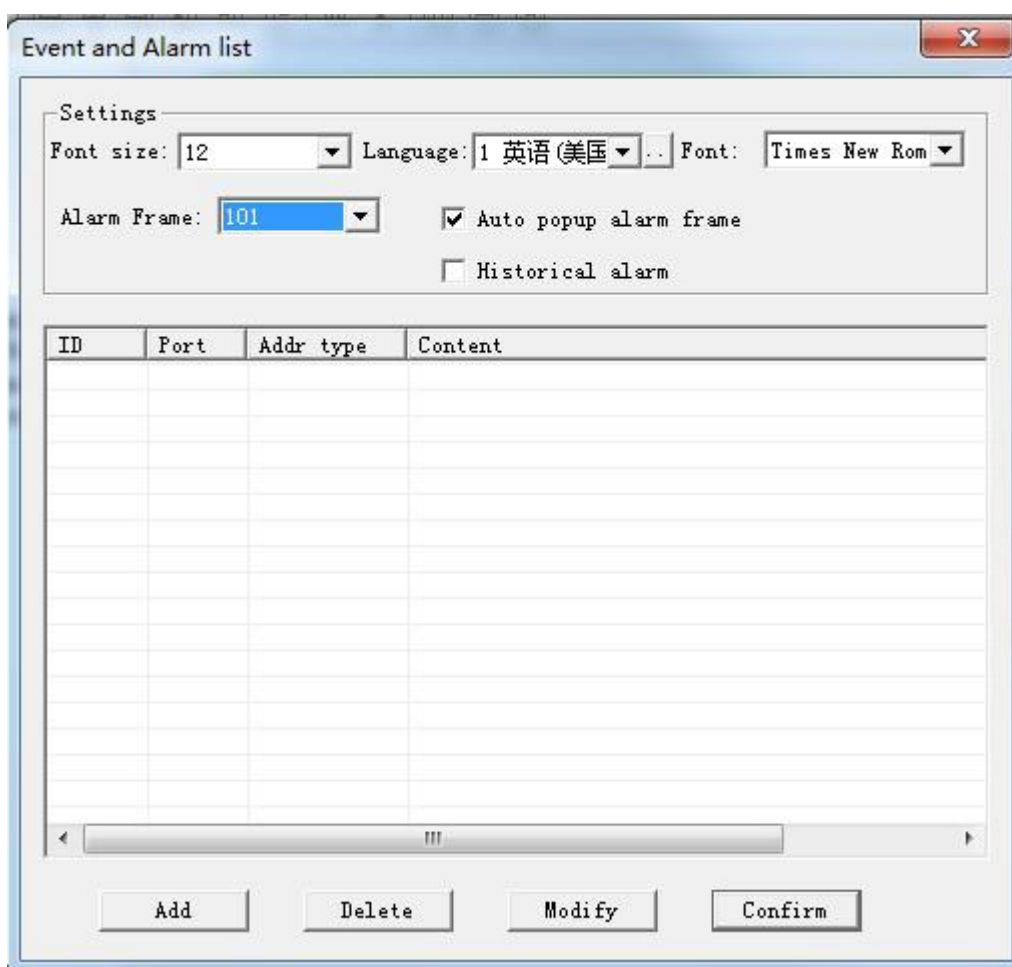

The list is blank for no information has been logged. Move the cursor to the “Alarm description” column and enter the information “Temp. over high”. Press “Enter” to show the screen as the following figure:



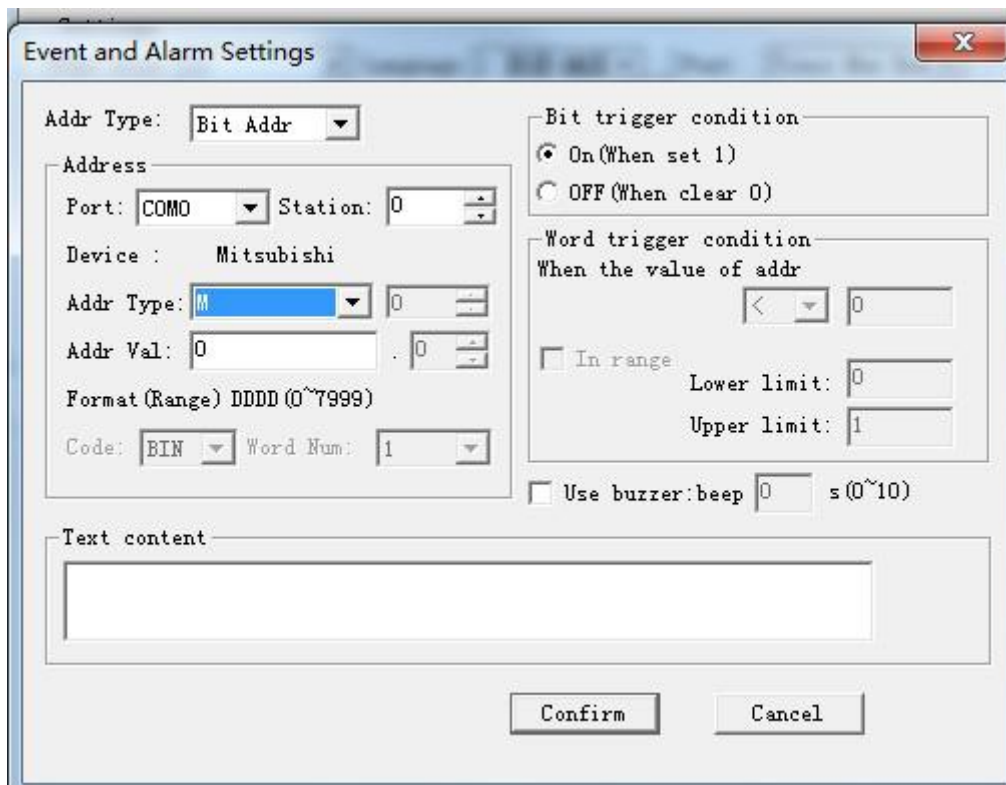

Input other information in the same way.

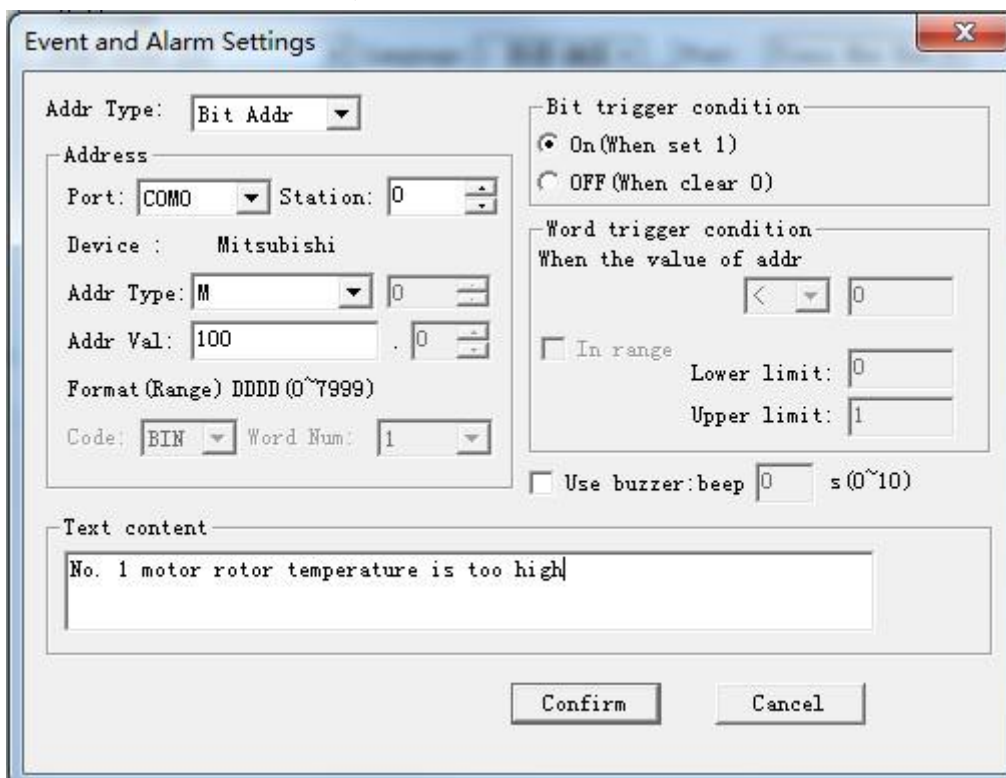

After entering all the information, set the coil type and address to M100 (for example) to indicate that the relays M100-M102 correspond to three pieces of alarm information.



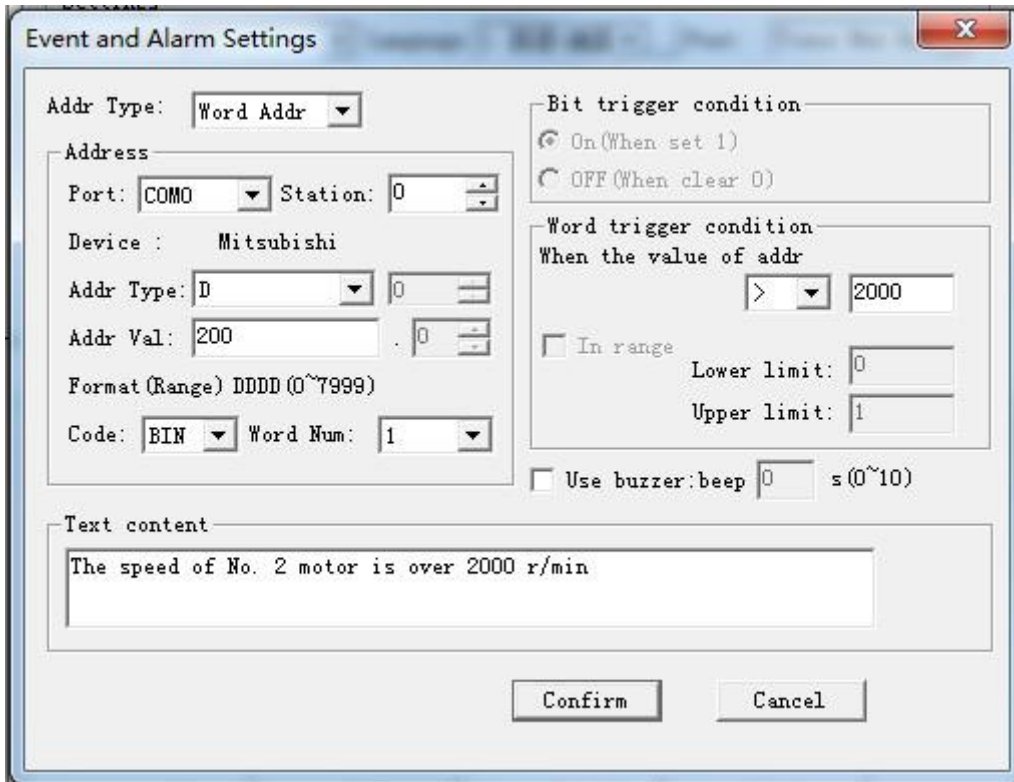

Address type: Including “status address” and “characters address” models.

Address: set the PLC connecting address as alarm monitoring address.

Status triggering condition: Choose 1-trigger (ON trigger) or 0-trigger(OFF trigger).

Characters triggering condition: When address type is set as characters address model, then set “characters triggering condition”. The condition includes >, <, =, ≤, ≥, ≠. When the condition is = or ≠, The value range changes to optional. When choosing value range, the “Top limit” and “lower limit” can be set, and it indicates the value changing range as the condition of = or ≠.

Buzzer trigger: It is optional condition. When it is chosen, it indicates that the buzzer will always make sounds during breakdown phase, the longest triggering action time is 10 seconds. When it is set as 0, it indicates the buzzer will always make sounds until the buzzer is confirmed or alarming is recovered.

The contents: The contents during alarming occurs shall be written.

When RTP1043 works normally, if M100 of PLC is set ON, D200 data is over 2000, it will pop up an alarm window and display as the figure below shows:

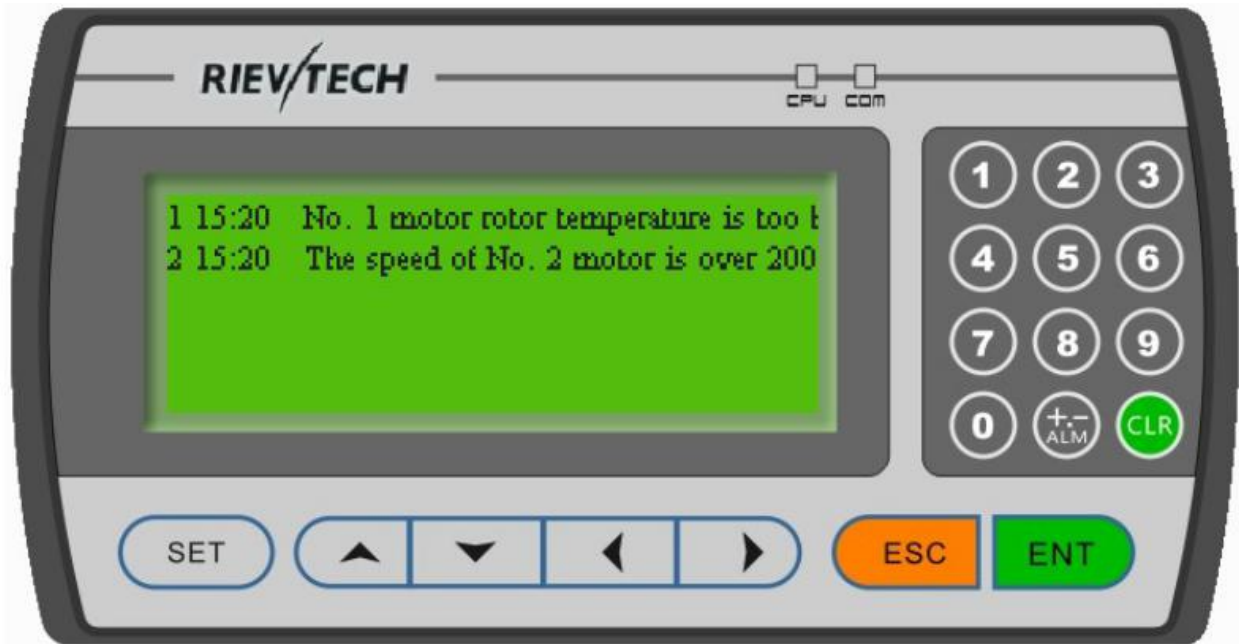

Seeing this alarm window, the operator can take some measures to solute the breakdowns. To return to the monitoring window, press [ESC].

When select the Show Historical Alarm option in alarm component ,the alarm list will display current alarm and history alarm.History alarm will display in the inverse colour.

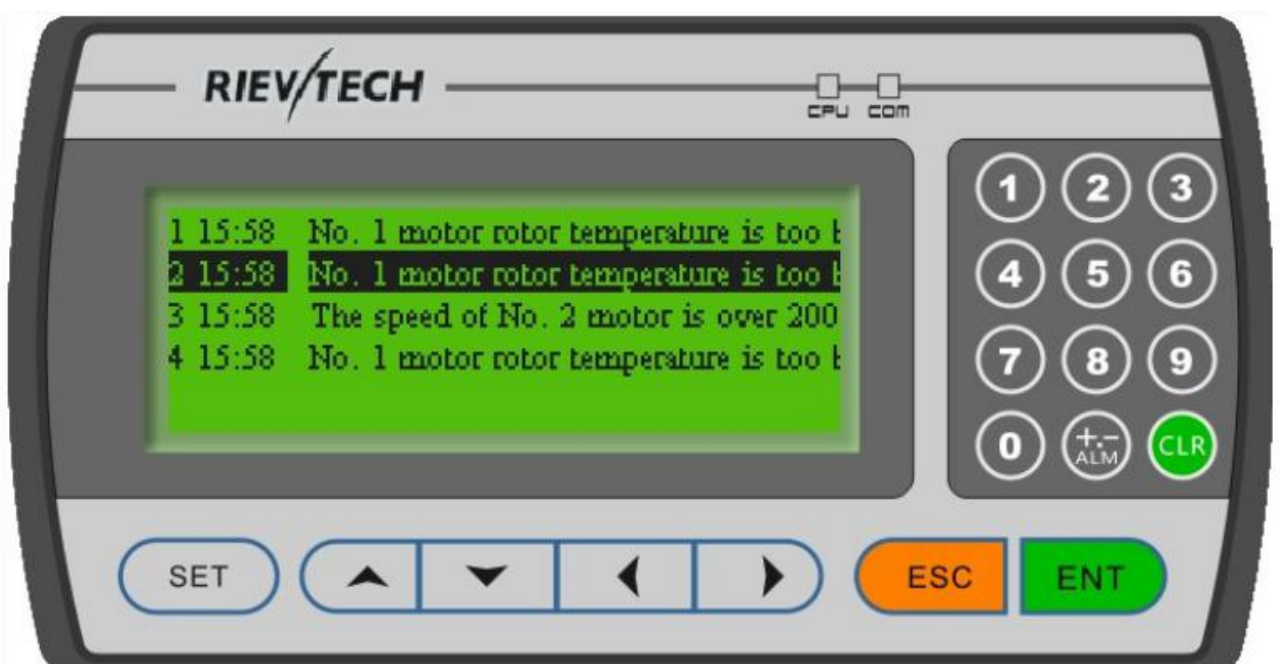
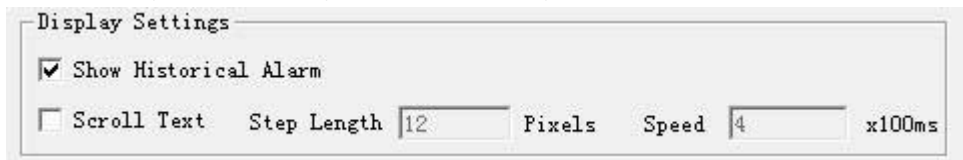

Press the up and down  key to flip.

Alarm information can be showed in the form of scroll text ,It's convenient to view the complete alarm information.Select the option of Scroll Text in the alarm component,set the the step length and speed, setting as follows:

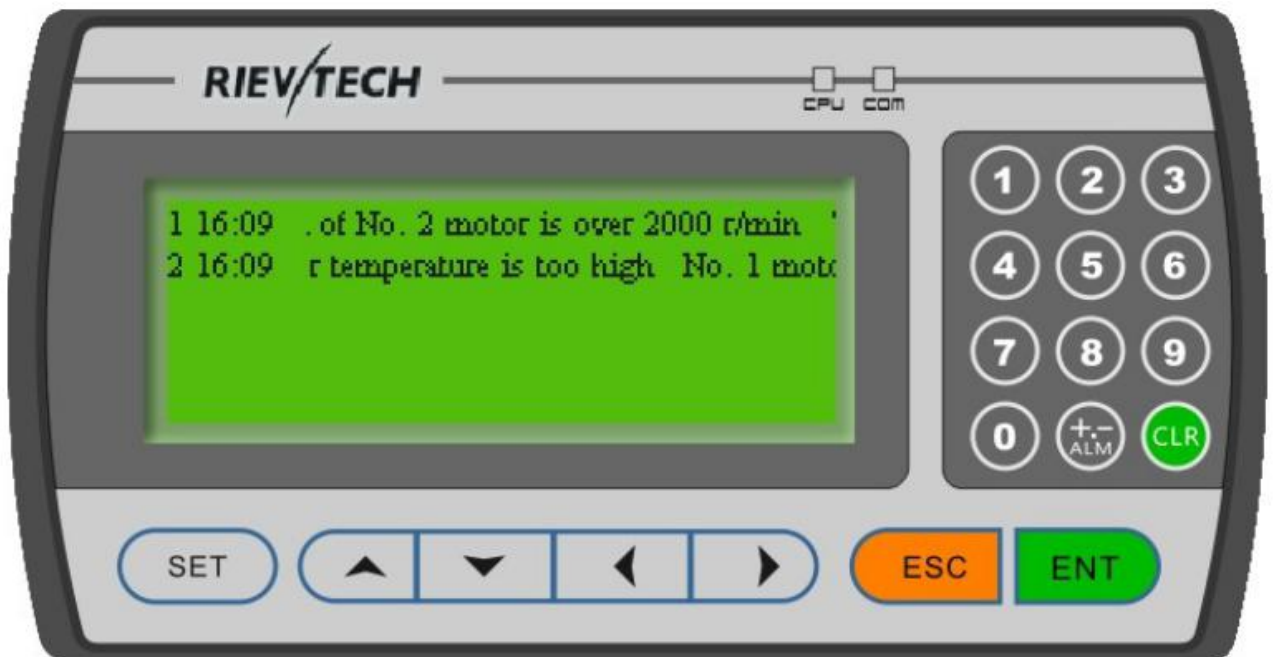
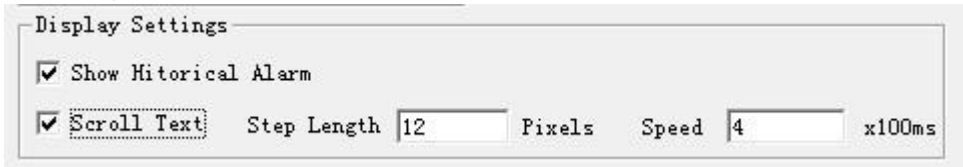

### 2.3 Project Saving

After the window editing is finished, the project files can be saved and downloaded to RTP1043 for shakedown test.

Press  to show the save dialog box:

Select the proper path and filename to save the file. The system defines “fpj” as the default external filename.

Enter the filename and select the proper path, then click “Save”.

## 2.4 Offline Simulation

After project writing finished, “Offline Simulation” function can preview window’s effect. Press  or “Tools/Offline Simulation” in the menu, then the “Offline Simulation” function can be realized. The indicating image is as below:

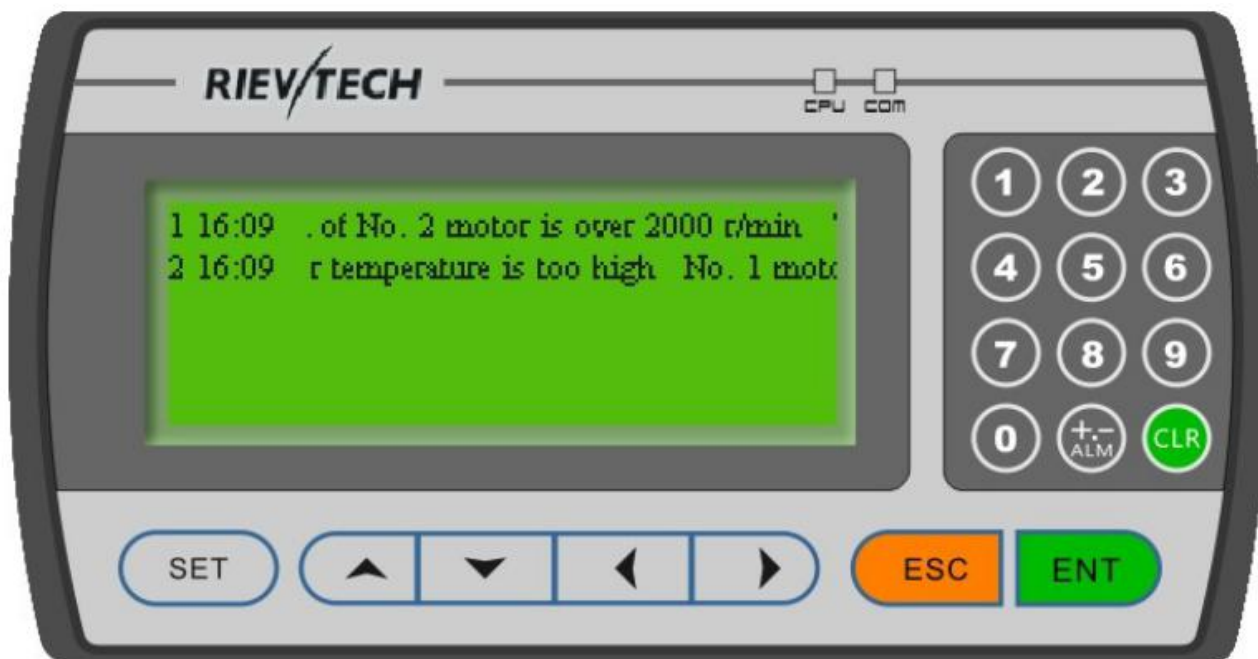

## 2.5 Download Window

Connect the USB Host of PC and USB Client connection of RTP1043 with the window downloading cable. Make sure that RTP1043 is connected with a 24V DC power supply. Press  to begin the downloading process. A dialog box will be displayed to indicate the progress of downloading:

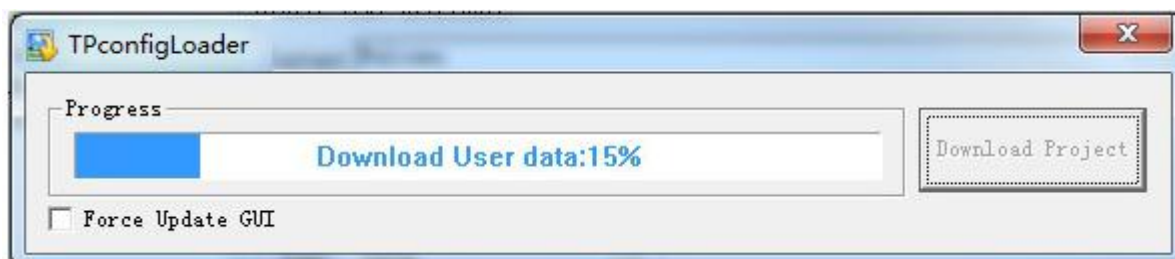

After all the transmission has been done, a dialog box will pop up to indicate that all the project windows have been downloaded to RTP1043.

Cut off the power of RTP1043 and remove the window downloading cable. Connect RTP1043 and PLC with the PLC communication cable.

Turn on RTP1043 and PLC. If the communication is successfully established, the system can be used for data monitoring and other functions. If there are some communication failures due to the incorrect communication parameters or some errors in cable connection, RTP1043 will show the text “COM0 PLC communication abnormal” in the middle, to indicate that RTP1043 is unable to connect with PLC.

**If RTP1043 can't communicate with PLC, please check the items in the list below:**

- Is the PLC type selected in the project same as that of the PLC being actually connected to?
- Are the addresses of the PLC register or coil visited in the project out of range?
- Is the station number of PLC correct?
- Are they connected with a communication cable?
- Is the connection of the cable correctly done?
- Are the PLC communication parameters configured correctly?
- Are the power supplies for PLC and RTP1043 OK? Are they power on?
- Contact the seller if the problem still can't be solved.

## Chapter 3. Manipulation

### 3.1 Communication

When the window downloading has finished, cut off the power supply and remove the downloading cable. Connect RTP1043 and PLC with a communication cable and check the setting of the PLC communication parameters. Turn on the power supply (24V DC for RTP1043), RTP1043 then start to work.

**Note:** RTP1043 can work whether the PLC is running or being programmed.

### 3.2 Shifting the Windows

Take the project windows edited in chapter 2 as an example to introduce the manipulation of RTP1043. RTP1043 displays window No.1 at first. (Because the initial window is window No.1.)

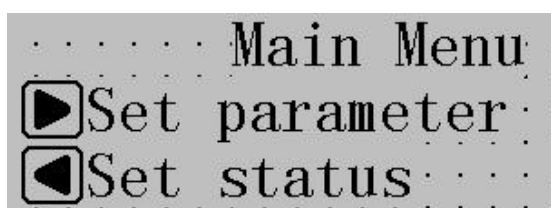

Window No.1 is a main menu window. Pressing the function keys can jump to sub-windows. Press[◀] to jump to parameter-setting window (window No. 10).

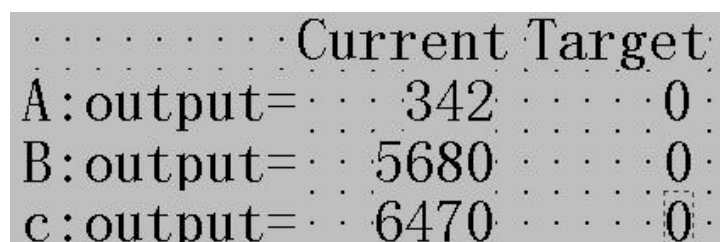

The data in the left column are the outputs of the three groups, corresponding to PLC addresses D100, D101 and D102 respectively.

### 3.3 Password

Password must be entered before changing the data. Press “SET” to show the window below:



Select 1 with the [▲],[▼] and [ENT] keys to log in; select 2 to log out; press [ESC] to return to the monitoring mode.

Select 1, the window will be like the figure below:

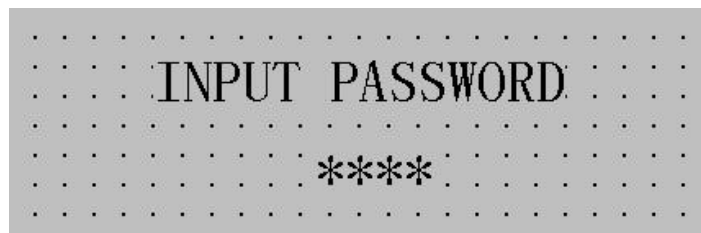

Input the password with the number keys, the number input will be displayed as “\*”. Press [ENT] when the password has been input.

If the password is correct, it will show the window below:

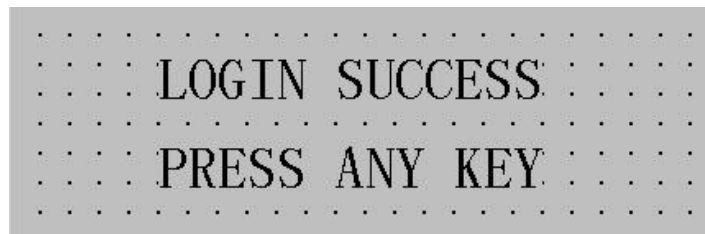

If the password is incorrect, it will show the window below:



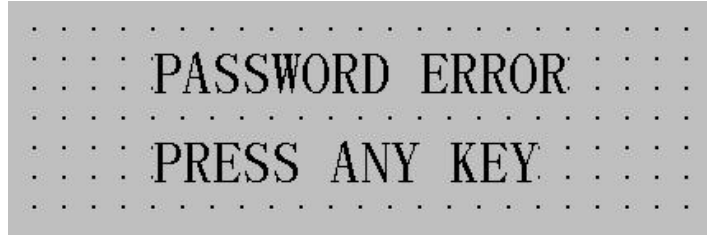

Select 2 to log out, it will show the window below:

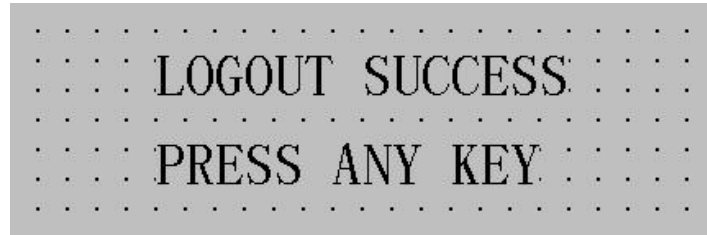

### 3.4 Changing the data

Log in and press [ENT], the target output of group A is flickering. So the data that will be changed first is the target output of group A. Press [CLR] to clear current value and input the new value with the number keys. If it is necessary to input a signed number, press [+/-] to change the sign. To input the hexadecimal number A-F, press [◀] and [▶] to change the digit being edited. Press [▲] and [▼] to change the value of that digit. The value will vary in the sequence 9-A-F-0.

Press [ENT] to confirm the entered data. The data been changed is written into the PLC register D110. The target output of group A will stop flickering, while that of group B starts to flicker. That means the setting for group A has been done and the setting for group B begins. To quit or skip the setting for group A, continue to press [SET]. The output of group A will remain the original value and stop flickering, and the output of group B starts to flicker to indicate that the data being changed is B output.

When the C output has been set, all data will be normally displayed, none of them flickering. To enter the setting mode again, press [SET].

### 3.5 Controlling the Switches

After changing the parameters, press [ESC] to return to the initial window (window No. 1) as the figure below shows:

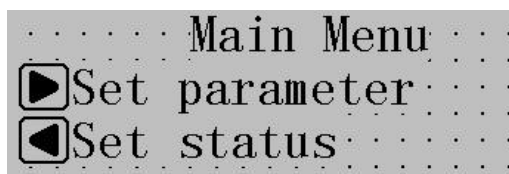

Press [◀] to jump to the status-setting window.

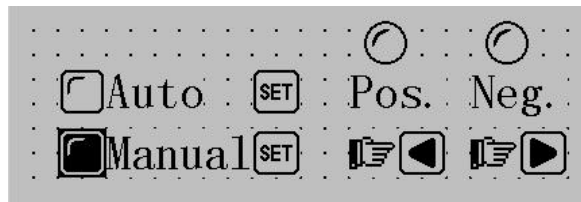

The device is in manual mode at this time. Press [SET] to change to auto mode. The relay M10 of PLC is set ON.

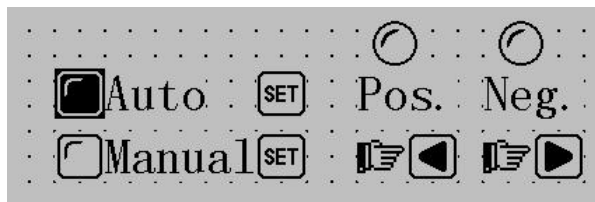

Press [◀] and hold, the machine will continue moving forward; press [▶] and hold, the machine will move backward continuously.

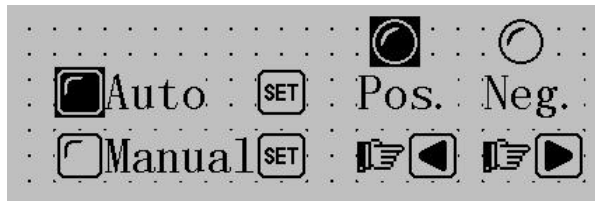

## Chapter 4. Connection with PLC

### 4.1 RIEVTECH

RTP1043 can communicate with rievtech PLC. The communication is done through the programming port/RS232 of PLC by RS232 cable or RS485 port of the PLC.

Item	Content
RTP1043 COM port	9-pin COM port
PLC COM port	Programming port or RS485 port
Default parameters	9600bps, 8bits, 1stop, None
Station No.	1
Distance (Max.)	10m for RS232, 1000m for RS485
Comm. mode	RS232 /RS485
Cable type	RS232 cable or RS485 module

#### RS232 CABLE

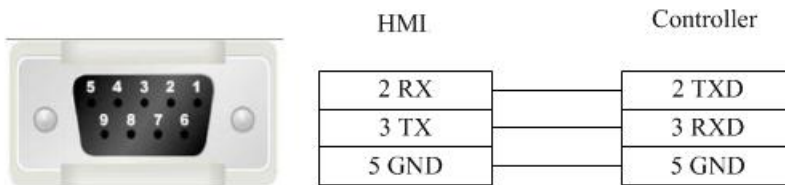

#### RS485 Connection

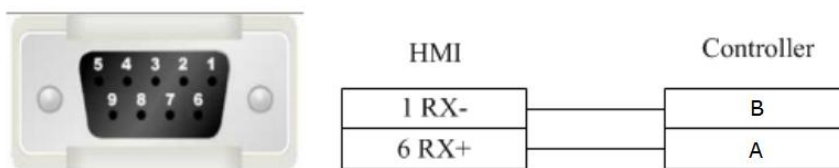







There are 2 available options for Rievtech PLCs, one is FBD mode(programming mode is Function block diagram), another is LAD mode(programming mode is Ladder)



If your PLC program is FBD, you need select **RIEVTECH FBD** as the device model. And the register address configuration is the modbus address. Modbus address is listed in below:



For example, if you want to read I1 status, you need select register type “I”, address is 0.

And if you want to read AF1 value, you need select register type “AF”, address is 3072.

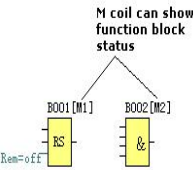

Register type	Register No.	Address (decimal)	format	property
<b>Digital input</b> Block in xLogicsoft:  Fashion:   Classic:   MODBUS Function code:02	EXM-12/ELC-12(CPU)(I1--I8) :	0~7	BIT	R
	EXM-E-8(EXT1)(I11--I18):	8~15		
	EXM-E-8(EXT2)(I21--I28):	16~23		
	EXM-E-8(EXT3)(I31--I38):	24~31		
	EXM-E-8(EXT4)(I41--I48):	32~39		
	EXM-E-8(EXT5)(I51--I58):	40~47		
	EXM-E-8(EXT6)(I61--I68):	48~55		
	EXM-E-8(EXT7)(I71--I78):	56~63		
	EXM-E-8(EXT8)(I81--I88):	64~71		
	PR-6(CPU)(I1--I4):	0~3		
	PR-12(CPU)(I1--I8):	0~7		
	PR-14/PR-18(CPU)(I1--IC):	0~11		
	PR-E-16(EXT1)(I11--I18):	12~19		
	PR-E-16(EXT2)(I21--I28):	20~27		
PR-E-16(EXT3)(I31--I38):	28~35			
PR-E-16(EXT4)(I41--I48):	36~43			
PR-E-16(EXT5)(I51--I58):	44~51			
.	.			
.	.			
PR-E-16(EXT16)(I161--I168):	132~139			
Address formula: $I_{(EXT) 1} = (Ext-1) * 8 + 12$ For example: $I_{51} = (5-1) * 8 + 12 = 44$				

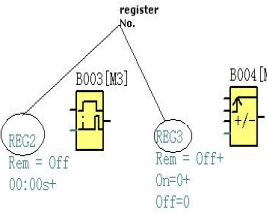
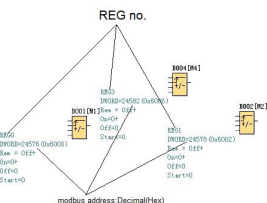

	<p>PR-24(CPU)(I1--IE):          PR-E-16(EXT1)(I11--I18):          PR-E-16(EXT2)(I21--I28):          PR-E-16(EXT3)(I31--I38):          PR-E-16(EXT4)(I41--I48):          PR-E-16(EXT5)(I51--I58):          .          .          PR-E-16(EXT16)(I161--I168):</p> <p>Address formula          : <math>I_{(EXT) 1} = (Ext-1) * 8 + 12</math>          For example: <math>I_{51} = (5-1) * 8 + 16 = 48</math></p>	<p>0~13          16~23          24~31          32~39          40~47          48~55          .          .          136~143</p>		
<p><b>4 cursors</b>          (Cursor key)</p> <p>Fashion: </p> <p>Classic: </p> <p>MODBUS          Function code:02</p>	<p>All type CPUs (C1-C4):</p>	<p>256~259</p>	<p>BIT</p>	<p>R</p>
<p>Digital input</p> <p>Fashion: </p> <p>Classic: </p> <p>MODBUS          Function code:01(read)          05(single write)</p>	<p>EXM-12/ELC-12(CPU)(Q1--Q4) :          EXM-E-8(EXT1)(Q11--Q18):          EXM-E-8(EXT2)(Q21--Q28):          EXM-E-8(EXT3)(Q31--Q38):          EXM-E-8(EXT4)(Q41--Q48):          EXM-E-8(EXT5)(Q51--Q58):          EXM-E-8(EXT6)(Q61--Q68):          EXM-E-8(EXT7)(Q71--Q78):          EXM-E-8(EXT8)(Q81--Q88):</p> <p>PR-6(CPU)(Q1--Q2):</p> <p>PR-12(CPU)(Q1--Q4):</p>	<p>0~7          8~15          16~23          24~31          32~39          40~47          48~55          56~63          64~71          0~1          0~3</p>	<p>BIT</p>	<p>R/W</p>

<p>15(Multiple Write)</p>	<p>PR-14/PR-18(CPU)(Q1--Q6):                  PR-E-16(EXT1)(Q11--Q18):                  PR-E-16(EXT2)(Q21--Q28):                  PR-E-16(EXT3)(Q31--Q38):                  PR-E-16(EXT4)(Q41--Q48):                  PR-E-16(EXT5)(Q51--Q58):                  .                  .                  PR-E-16(EXT16)(Q161--Q168)                  Address formula: <math>Q_{(EXT) 1} = (Ext-1) * 8 + 8</math>                  For example: <math>Q_{51} = (5-1) * 8 + 8 = 40</math></p>	<p>0~5                  8~15                  16~23                  24~31                  32~39                  40~47                    128~135</p>		
	<p>PR-24(CPU)(Q1--QA):                  PR-E-16(EXT1)(Q11--Q18):                  PR-E-16(EXT2)(Q21--Q28):                  PR-E-16(EXT3)(Q31--Q38):                  PR-E-16(EXT4)(Q41--Q48):                  PR-E-16(EXT5)(Q51--Q58):                  .                  .                  PR-E-16(EXT16)(Q161--Q168)                  Address formula: <math>Q_{(EXT) 1} = (Ext-1) * 8 + 10</math>                  For example: <math>Q_{51} = (5-1) * 8 + 10 = 42</math></p>	<p>0~9                  10~17                  18~25                  26~33                  34~41                  42~49                    130~137</p>		
<p>M(0x)</p>  <p>MODBUS function code01(read)</p>	<p>PR-6&amp; PR-12-E(M1--M64):                    EXM-12/ELC-12(M1--M512):                    PR-12/PR-14(M1--M512):                    PR-18/PR-24(M1--M1024):</p>	<p>256~319                    256~767                    256~767                    256~1279</p>	<p>BIT</p>	<p>R</p>
<p><b>Digital Flag</b></p>  <p>Fashion:</p>	<p>PR-6/PR-12-E(F1--F64):</p>	<p>1536~1567</p>	<p>BIT</p>	<p>R/W</p>

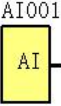
<p>Classic: </p> <p>MODBUS function code:01(read) 05(single Write) 15(Multiple Write)</p>	<p>EXM-12/ELC-12-N(F1--F128):</p>	<p>1536~1663</p>				
<p><b>REG</b></p>  <p>MODBUS function code: 03(read) 16(Multiple Write)</p>	<p>PR-6/PR-12-E(REG0--REG64):</p>	<p>0~63</p>	<p>LONG</p>	<p>R/W</p>		
<p><b>REG/DW (Updated version)</b></p>  <p>MODBUS function code (read) 16(Multiple Write)</p>	<p>For All CPUs: REG0: REG1: REG2: REG3: . . REG10</p>	<p>25476 25478 25480 25482 . . 25496</p>			<p>DWORD</p>	<p>R/W</p>
<p>Address formula: <math>REG_x = 25476 + 2x</math> For example, <math>REG_{20} = 25476 + 2 \times 20</math> <math>= 25476 + 40</math> <math>= 25516</math></p>	<p>PR-18/PR-24(REG0--REG1023)</p>	<p>0~1023</p>				
<p>Analog input Fashion: </p>	<p>PR-6/PR-12-E/PR-12(AI1--AI4):</p>	<p>1024~1279</p>	<p>Signed short</p>	<p>R</p>		

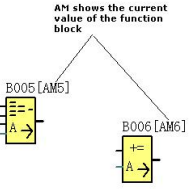

<p>Classic: </p> <p>MODBUS Function code: 03(read)</p>	<p>PR-14/PR-18/PR-24(AI1--AI6):          PR-E-16(EXT1)(AI11-AI14):          PR-E-16(EXT2)(AI21-AI24):          PR-E-16(EXT3)(AI31-AI34):          .          .          PR-E-16(EXT16)(AI161-AI164):          Address formula: <math>AI_{(EXT) 1} = (Ext-1) * 8 + 1032</math>          For example:  <math>AI_{51} = (5-1) * 8 + 1032 = 1072</math></p>	<p>1024~1029          1032~1039          1040~1047          1048~1055          .          .          1152~1159</p>		
	<p>EXM-12/ELC-12-N(AI1--AI4):          EXM-E(EXT1)(AI11-AI14):          EXM-E(EXT2)(AI21-AI24):          EXM-E(EXT3)(AI31-AI34):          EXM-E(EXT4)(AI41-AI44):          EXM-E(EXT5)(AI51-AI54):          EXM-E(EXT6)(AI61-AI64):          EXM-E(EXT7)(AI71-AI74):          EXM-E(EXT8)(AI81-AI84):</p>	<p>1024~1027          1032~1039          1040~1047          1048~1055          1056~1063          1064~1071          1072~1079          1080~1087          1088~1095</p>		
<p>Analog output Fashion: </p> <p>Classic: </p>	<p>PR-12 (AQ1-AQ2)</p>	<p>1280~1281</p>	<p>Signed short</p>	<p>R/W</p>
<p>MODBUS function: 03(read)          06(Single Write)          16(Multiple Write)</p>	<p>PR-14/PR-18/PR-24(AQ1-AQ2):          PR-E-AQ(EXT1)(AQ11-AQ12):          PR-E-AQ(EXT2)(AQ21-AQ22):          .          .          PR-E-AQ(EXT16)(AQ161-AQ162)          :          Address formula: <math>AQ_{(EXT) 1} = (Ext) * 2 + 1280</math>          For example: <math>AQ_{161} = 16 * 2 + 1280 = 1312</math></p>	<p>1280~1281          1282~1283          1284~1285          .          .          1312~1313</p>		

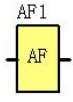
	EXM-12/ELC-12-N(AQ1--AQ2): EXM-E(EXT1)(AQ11-AQ12): EXM-E(EXT2)(AQ21-AQ22): EXM-E(EXT3)(AQ31-AQ32): EXM-E(EXT4)(AQ41-AI42): EXM-E(EXT5)(AQ51-AI52): EXM-E(EXT6)(AQ61-AQ62): EXM-E(EXT7)(AQ71-AQ72): EXM-E(EXT8)(AQ81-AQ82):	1280~1281 1282~1283 1284~1285 1286~1287 1288~1289 1290~1291 1292~1293 1294~1295 1296~1297		
Analog AM  <p>AM shows the current value of the function block</p> 	PR-6/PR-12-E(AM1--AM64):	1536~1599	Signed short	R
	EXM-12/ELC-12/PR-12/PR-14 (AM1--AM512):	1536~2047		
	MODBUS Function code: 03(read)	PR-14/PR-24(AM1--AM1024):		
Analog AF Fashion:  Classic:  MODBUS Function: 03(read) 06(Single Write) 16(Multiple Write)	PR-6/PR-12-E(AF1--AF64):	3072~3103	Signed short	RR/W
	PR-12/PR-18/PR-24/EXM/ELC-12-N(AF1--AF256):	3072~3327		
HEG	EXM-12/ELC-12/PR-12 (HEG0--HEG511):	2560~3071	Word	R

 MODBUS function code:03(read) 16(Multiple Write)	PR-6/PR-12-E(HEG0--HEG63):	2560--2623		
	PR-18/PR-24(HEG0-HEG511): (HEG512--HEG1023):	2560--3071 19456--19967		
RTC  MODBUS function code:03(read) 16(Multiple Write)	All series CPU	Year:3328 Month:3329 Day:3330 Hour:3331 Minute:3332 Second:3333 Week: 3334	Signed short	R/W

If your PLC program is Ladder, you need select **RIEVTECH LAD** as the device in the TPConfig. And the register address configuration is the number of the corresponding register. For example:

If you want to read I0.0 status, you just only need select I0.0, and if you want to read VW0 value, you donot need use the Modbus address for VW0 anymore.

Below table shows the all the kinds of the register in ladder program. The modbus address is only for you if you selected the Modbus RTU as the communication driver in TPConfig.

Bit		Modbus Adr.	Modbus code	R/W
I	I0.0--I31.7	0--255	02	R
SM	SM0.0--SM551.7	300--4715	02	R
T	T0-T255	5000--5255	02	R
C	C0-C255	5500--5755	02	R
Q	Q0.0--Q31.7	0--255	01/05 (15)	R/W
M	M0.0--M31.7	320--575	01/05 (15)	R/W
S	S0.0--S31.7	680--935	01/05 (15)	R/W
V	V0.0--V8063.7	1024--65535	01/05 (15)	R/W

Word		Modbus Adr.	Modbus code	R/W
VW	VW0--VW8190	0--8190	03/06 (16)	R/W
MW	MW0--MW30	8200--8230	03/06 (16)	R/W
SMW	SMW0--SMW550	8300--8850	03/06 (16)	R/W
SW	SW0--SW30	9000--9030	03/06(16)	R/W
T	T0-T255	9100--9355	03/06 (16)	R/W
C	C0-T255	9500--9755	03/06 (16)	R/W
AIW	AIW0--AIW178	0--178	04	R

AQW	AQW0--AQW178	200--378	04	R
IW	IW0--IW30	400--430	04	R
QW	QW0--QW30	500--530	04	R

DWord		Modbus Range	Adr. Address calculation formula	Modbus code	R/W
VD	VD0--VD8188	10000--26376	VD: 10000+(2*No.)	03/(16)	R/W
MD	MD0--MD28	30000--30056	MD: 30000+(2*No.)	03/(16)	R/W
SMD	SMD0--SMD548	31000--32096	SMD: 31000+(2*No.)	03/(16)	R/W
SD	SD0--SD28	33000--33056	SD: 33000+(2*No.)	03/(16)	R/W
ID	ID0--ID28	600--656	ID: 600+(2*No.)	04	R
QD	QD0--QD28	700--756	QD: 700+(2*No.)	04	R

## 4.2 Mitsubishi FX Series

RTP1043 can communicate with all types of Mitsubishi FX series PLC. The communication is done through the programming port of PLC or the FX2N-422BD module of the FX2N series.

Item	Content
RTP1043 COM port	9-pin COM port
PLC COM port	Programming port or FX2N-422BD
Default parameters	9600bps, 7bits, 1stop, Even
Station No.	0
Distance (Max.)	70m
Comm. mode	RS422 / programming port
Cable type	FE1-FX-CAB0
Switch relay address	M000---511
Switch relay address	X000---377 (octal digits)
Switch relay address	Y000---377 (octal digits)
Switch relay address	M0000---7999
Switch relay address	M8000---9999
Switch relay address	C_bit 0--- 255
Switch relay address	T_bit 0 --- 255
Register parameter address	D0000---7999
Register parameter address	SD8000---9999

Register parameter address	C_word 0---199
Register parameter address	C_dword 200---255
Register parameter address	T_word 0---255

**Special cable FE1-FX-CAB0 (also for FX0S, FX0N, FX1S,FX1N and FX2N Series PLC)**

**Note: The address range refers to text displayer supporting range, perhaps with some difference of PLC address range. Please refer to PLC actual address range.**

**FE1-FX-CAB0 cable connecting diagram:**

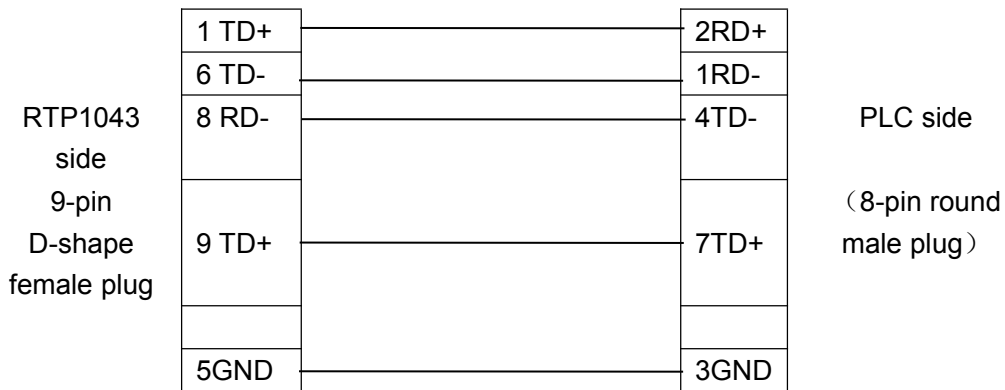

**Pin map of 8-pin round female socket**  
 (Note that the right-left direction of the male plug is reverse to that of the female socket)

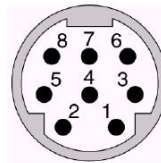

### 4.3 SIEMENS S7-200 Series

RTP1043 can communicate with the programming port or external communication port of S7-200 PLC through the PPI protocol.

Item	Content
RTP1043 COM port	RS485 COM port
PLC COM port	Programming port or external COM port
Default parameters	9600bps, 8bits, 1stop, Even
Station No.	Range:2—31, default value: 2
Distance (Max.)	100m (twisted pair wire)
Comm. mode	RS485 2W
Cable type	FE1-S7-200-CAB0
Switch relay address	M.B 0.0----255.7
Switch relay address	V.B 0.0-----8191.7

Switch relay address	I.B 0.0 -----127.7
Switch relay address	Q.B 0.0----127.7
Register parameter address	VW000---10238
Register parameter address	VD000---10238
Register parameter address	C000----255
Register parameter address	T000----255

**Connection guidance of MD2-S7-200 cable**

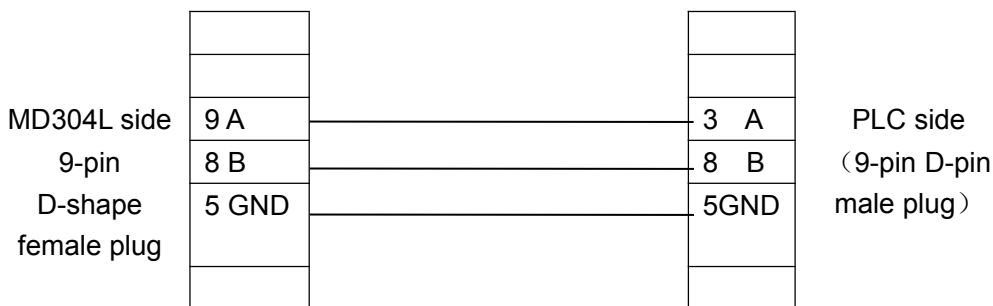

(It is recommended to use the S7-200 programming cable to be the communication cable.)

**4.4 OMRON C Series**

RTP1043 can communicate with PLC of OMRON, CPM and CQM series through HOST-Link protocol.

Item	Content
RTP1043 COM port	9-pin communication port
PLC COM port	Programming port or external COM port
Default parameters	9600bps, 7bits, 2stop, Even
Station No.	Range: 0-99, default: 0
Distance (Max.)	15m
Comm. mode	RS232
Cable type	FE1-CQM-CAB0/1
Switch relay address	H_bit 0.00---99.15
Switch relay address	D_bit 0.00---6655.15
Switch relay address	LR_bit 0.00---63.15
Switch relay address	A_bit 0.00---959.15
Switch relay address	CIO_bit 0.00---511.15
Register parameter address	A000---959
Register parameter address	CIO 000---511
Register parameter address	CNT000---511

Register address	parameter	D000---6655
Register address	parameter	H00---99
Register address	parameter	LR00---63
Register address	parameter	TIM000---511

**Note:** CPM1A and CQM1-CPU11 has only one COM port, so the signal of the programming port must be converted to RS232 signal with the connection cable or communication module provided by OMRON (CIF01-CAB) when connecting with RTP1043.

**Connection guidance of FE1-CQM-CAB0, FE1-CQM-CAB1 cable**

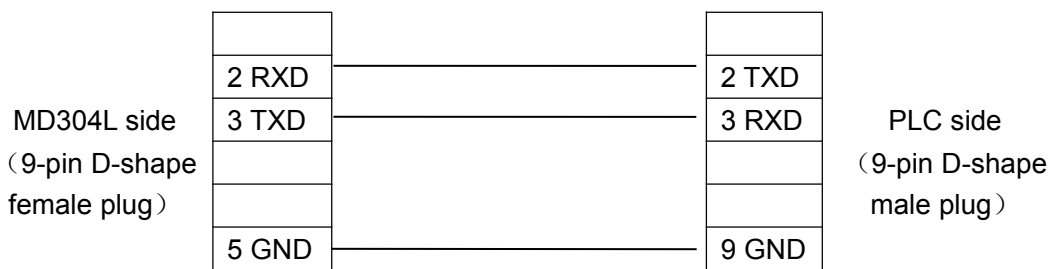

**NOTE:THE CPU MUST WORK ON “MONITOR MODE”**

### 4.5 MODBUS RTU

RTP1043 can communicate to the programming port of PLC through MODBUS RTU protocol.

Item	Content
RTP1043 COM port	RS485 port
PLC COM port	Programming port
Protocol	Modbus RTU
Default parameters	19200bps, 8bit, 1stop, NONE
Station No.	1 – 255, default:1
Distance (Max.)	100m (twisted pair wire)
Comm. mode	RS485/232
Cable type	FE1-MDBS-CAB0
Switch relay address	0X001---65535
Switch relay address	1X001---65535
Register parameter address	4X001---65535
Register parameter address	3X001---65535

**Connection guidance of FE1-MDBS-CAB(RS485) cable**





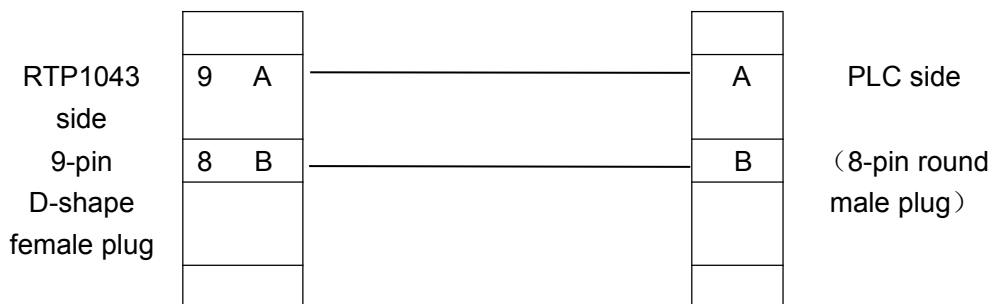

**Connection guidance of E1-MDBS-CAB(RS422)**

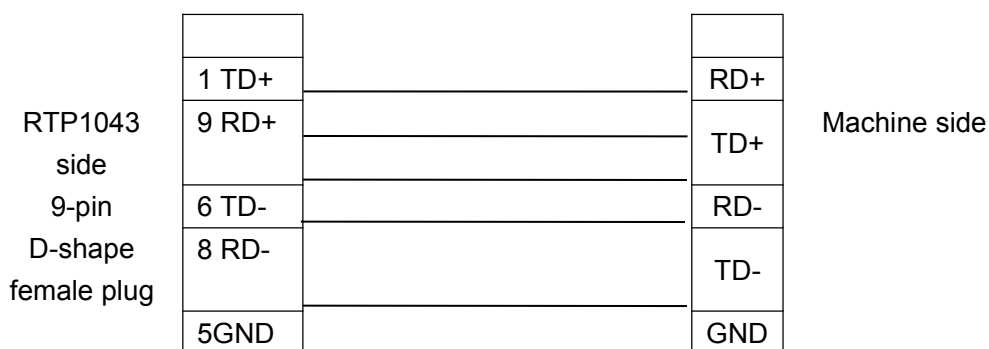

NOTE: the relation between HMI and PLC

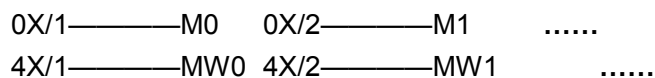

Pin map of 8-pin round female socket

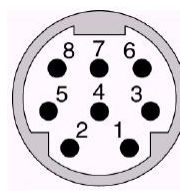

**4.6 Delta DVP Series**

MD304L can communicate with the delta DVP series PLC. The programming port of PLC is used as the communication port.

Item	Content
RTP1043 COM port	9-pin COM port
PLC COM port	Programming port
Default parameters	9600bps、7bits、1stop、Even
Station No.	Range: 1-254, default: 1
Distance (Max.)	15m
Comm. mode	RS232
Cable type	MD2-DVP
Inner relay address	M0-M999

Register address	parameter	D0-D599
------------------	-----------	---------

**Connection guidance of MD2-DVP cable**

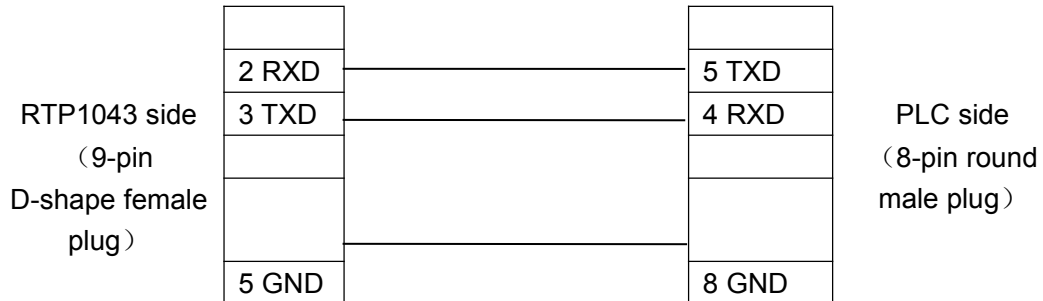

Pin map of 8-pin round female socket

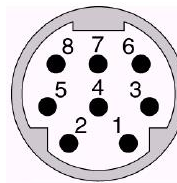

**4.7 Panasonic FP Series**

RTP1043 can communicate with Panasonic FP PLC. The communication port is the programming port of PLC or external communication port.

Item	Content
RTP1043 COM port	9-pin COM port
PLC COM port	Programming port or external COM port
Default parameters	9600bps、8bits、1stop、Odd
Station No.	Range: 1-32, default: 1
Distance (Max.)	15m
Comm. mode	RS232
Cable type	MD2-FP1, MD2-FP
Inner relay address	R0000-R875F
Register address	parameter DT0000-D9999

**Connection guidance of MD2-FP1 cable**

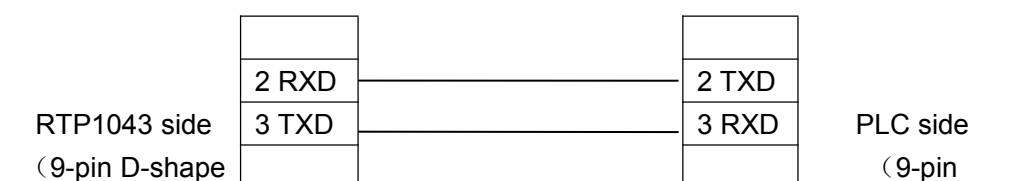

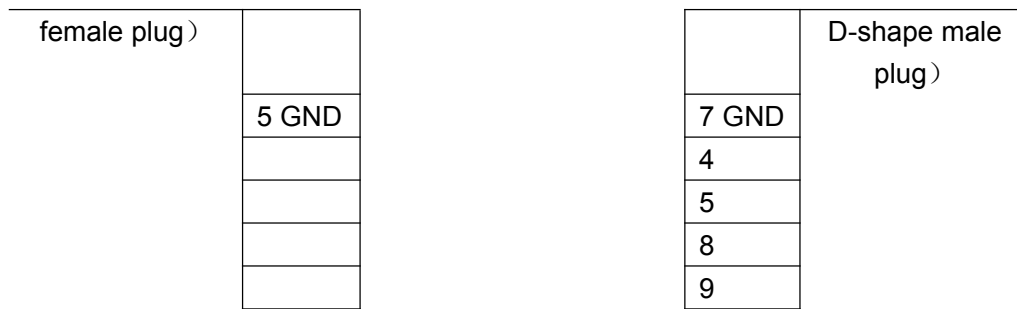

**Connection guidance of MD2-FP cable**

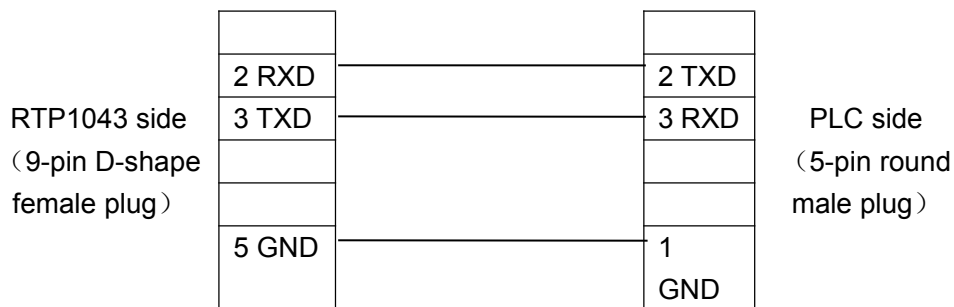

**Pin map of Panasonic 5-pin round female socket**

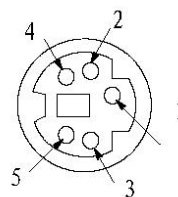

### 4.8 LG Master-K CNet Series

RTP1043 can communicate with the LG Master-K series PLC. The communication port is Port2.

Item	Content
RTP1043 COM port	9-pin COM port
PLC COM port	Port2
Default parameters	9600bps、8bits、1stop、None
Station No.	Range: 0-31, default: 1
Protocol	CNet
Distance (Max.)	15m
Communication pattern	RS232
Cable type	MD2-LG-CNet
Inner relay address	M000-M191F
Register address	parameter D0000-D4500

**Connection guidance of MD2-LG-CNet cable**

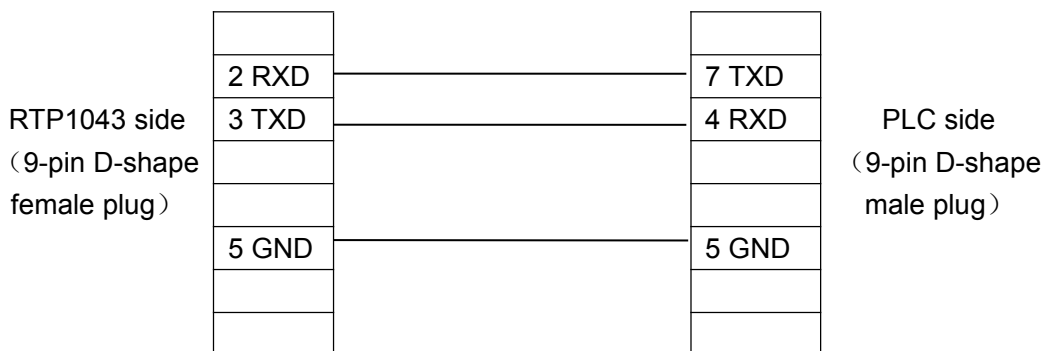

**NOTE:THE PLC SWITCH SET—1 (OFF), 2 (ON)**

**4.9 LG Series supporting Modbus protocol**

RTP1043 can communicate with the LG series PLC that support Modbus protocol. The communication port is Port2.

Item	Content
RTP1043 COM port	9-pin COM port
PLC COM port	Port2
Default parameters	9600bps、8bits、1stop、Even
Station No.	Range: 1-31, default: 1
Protocol	Modbus RTU
Distance (Max.)	15m
Communication pattern	RS232
Cable type	MD2-LG-Mod
Inner relay address	M000-M191F
Register parameter address	D0000-D4500

**Connection guidance of MD2-LG-Mod cable**

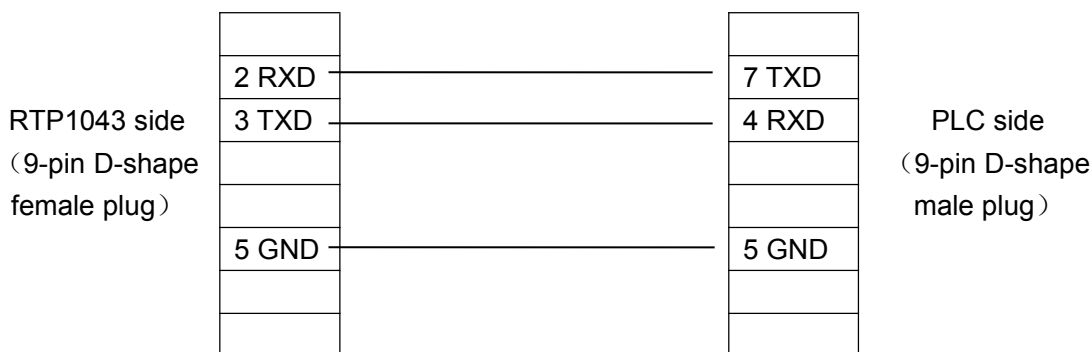

**NOTE:THE PLC SWITCH SET—1 (OFF), 2 (ON)**

### 4.10 LG Master-K 120S Programmable port

RTP1043 can communicate with the LG Master-K 120s PLC via Programmable port.

Item	Content
RTP1043 COM port	9-pin COM port
PLC COM port	Programmable port
Default parameters	38400bps、8bits、1stop、none
Station No.	Range: 1-31, default: 1
Protocol	Programmable port protocol
Distance (Max.)	15m
Communication pattern	RS232
Cable type	MD2-LG-Mod
Inner relay address	M000-M191F
Register parameter address	D0000-D4500

#### Connection guidance of MD2-LG-Mod cable

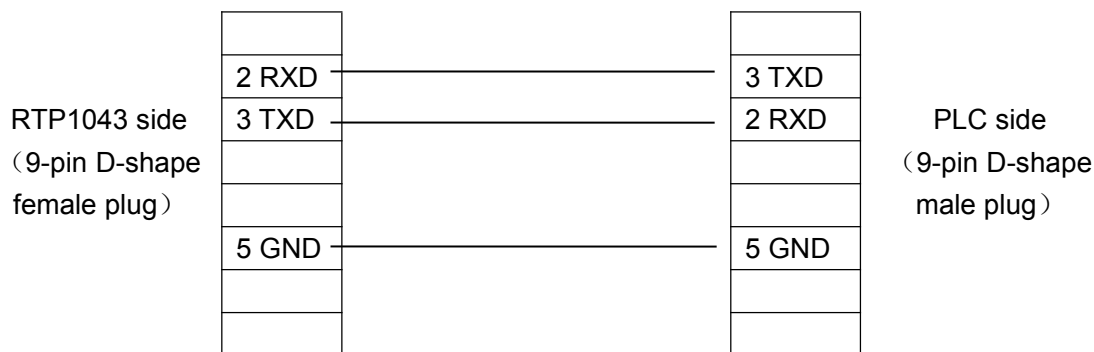

**NOTE:THE PLC SWITCH SET—1 (OFF), 2 (ON)**

### 4.11 FACON Series

RTP1043 can communicate with FACON MU/MC series PLC. The communication port is Port0.

Item	Content
RTP1043 COM port	9-pin COM port
PLC COM port	Programming port
Default parameters	9600bps、7bits、1stop、Even
Station No.	Range: 1-254, default: 1
Protocol	FACON communication protocol
Distance (Max.)	15m

Comm. mode	RS232
Cable type	MD2-FACON
Inner relay address	M0000-M2001
Register parameter address	R0000- R8071

**Connection guidance of MD2-FACON cable**

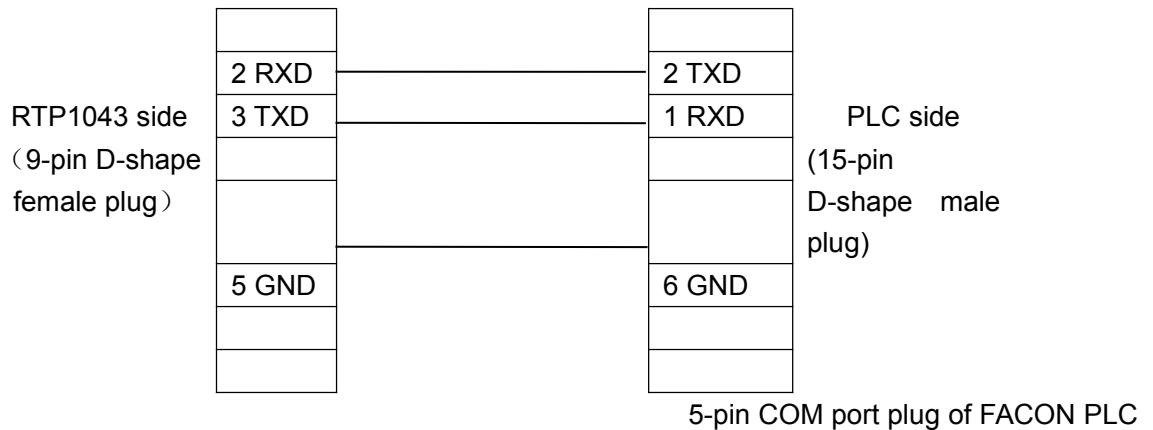

**4.12 KOYO S Series**

MD204 can communicate with the KOYO S series PLC. When communicating with SZ-4, either Port1 or Port2 can be used as communication port.

Item	Content
RTP1043 COM port	9-pin COM port
PLC COM port	Programming port or external communication port
Default parameters	9600bps、8bits、1stop、ODD
Station No.	Station 1
Distance (Max.)	15m
Comm. mode	RS232
Cable type	MD2-SZ for SZ、SH、SH series MD2-SG for SU、SG series
Inner relay address	M000-M377
Register parameter address	R2000-R3777

**Note: All addresses are shown in octal mode**

**Connection guidance of MD2-SZ cable**

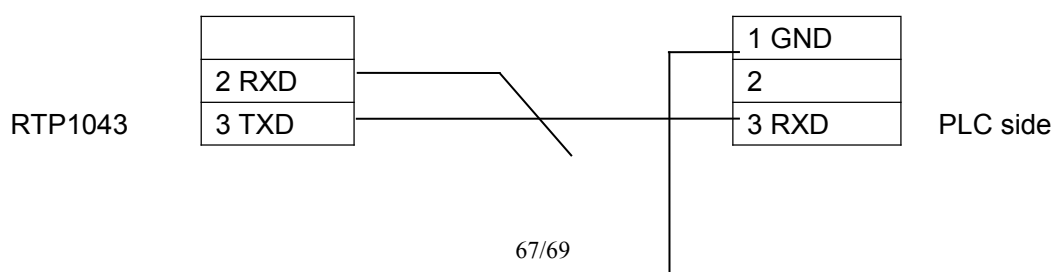



Pin map of RJ12 6-pin female socket

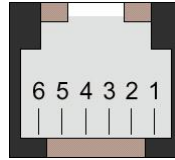

**Connection guidance of MD2-SG cable**

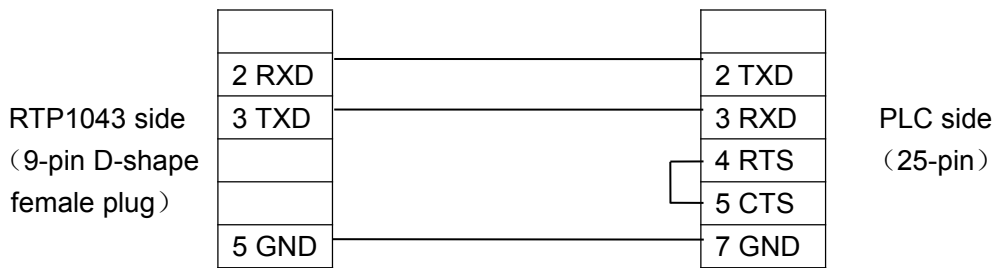

## Appendix: system special register definition

Address	Type	Description
LW254~255	DWORD	Password input
LW253	WORD	Current password level, with R/W property, but only allowed to set int lower password level.
LW252	WORD	RTC: Second
LW251	WORD	RTC: Minute
LW250	WORD	RTC: Hour
LW249	WORD	RTC: Date
LW248	WORD	RTC: Month
LW247	WORD	RTC: Year
LW.B 246.1	BIT	If is keeping ON, basic window exit operation is unavailable; When pop-out window close, the initial operation of basic window is not available as well.
LW.B 246.2	BIT	( Only be available under simulation mode ) ON simulate if COM0 timeout
LW.B 246.3	BIT	( Only be available under simulation mode ) ON simulate if COM0 error
LW.B 246.4	BIT	( Only be available under simulation mode ) ON simulate if COM1 timeout
LW.B 246.5	BIT	( Only be available under simulation mode ) ON simulate if COM1 error